



Gurnee
Park District

Policy Manual

Approved by Board of Park Commissioners 1/16/2024

Contents

MISSION	4
SECTION 1 BOARD POLICIES	5
INTRODUCTION	5
1.1 Board Membership	7
1.2 Ethics and Conduct	11
1.3 Powers and Duties of the Board.....	20
1.4 Officers of the Board	22
1.5 Appointed Personnel of the Board.....	23
1.6 Committees of the Board	27
1.7 Board Meetings.....	28
SECTION 2 ADMINISTRATION POLICIES.....	37
INTRODUCTION	37
Purpose	37
Administrative Office	37
Official Records	37
Structure of Authority	37
Park and Facility Use.....	37
Control of Parks	38
2.1 Use of Viking Park Band Shell Policy.....	39
2.2 Naming of Parks Policy	40
2.3 Non-Discrimination Policy	41
2.4 Smoke Free Environment Policy	43
2.5 Environmental Policy	44
2.6 Comprehensive Needs Assessment Policy	45
2.7 Community/Affiliate Group/Intergovernmental Agreement Policy	46
2.8 Identity Protection Policy	47
2.9 Sponsorship Policy	48
2.10 Cooperation with Homeowners Associations Policy.....	50
2.11 Safety Policy.....	51
2.12 Employment of Certified and Professionally Trained Staff Policy	52
2.13 Acceptance of Gifts Policy	53
2.14 Human Rights Policy	54
SECTION 3 FINANCE POLICIES.....	57
3.1 Purchasing Policy	57
3.2 Disposal of Fixed Assets Policy	63

GURNEE PARK DISTRICT POLICY MANUAL

3.3 Capital Replacement/Development Fund Policy 65

3.4 Land Cash Donation Policy 66

3.5 Investment Policy 69

3.6 Capital Asset Policy..... 78

3.7 Bill Payment Policy 80

3.8 Fund Balance Policy 81

3.9 Internal Control Policy..... 84

3.10 Budget Policy..... 87

3.11 Debt Issuance and Management Policy 89

3.12 Payment Card Industry (PCI) Data Security Policy..... 92

3.13 Contracts Policy..... 93

3.14 Reimbursement of Employee and Officer Travel, Meal and Lodging Expenses 111

SECTION 4 RECREATION POLICIES..... 116

4.1 Employees with Chronic Infectious Diseases..... 116

4.2 Participants with Chronic Infectious Diseases..... 117

4.3 Mobility Device Use Policy..... 118

4.4 Service Animal Policy 122

4.5 Revenue Policy 127

4.6 Abused and Neglected Child Reporting 129

4.7 Recreation Planning, Development and Evaluation Policy 130

4.8 Soccer Goal Safety and Education Policy 131

4.9 Financial Assistance Policy 140

4.10 Volunteer Policy 141

4.11 Employee and Volunteer Recognition Policy..... 143

4.12 Policy on Criminal Background Check for Contractual Program Providers 146

APPENDIX A: PERSONNEL POLICY MANUAL..... 147

APPENDIX B: SAFETY PROCEDURE MANUAL..... 148

GURNEE PARK DISTRICT

MISSION

Promoting fun • Preserving nature.

VISION

As a nationwide leader in our field, be the premier provider of community driven and innovative park and recreation experiences, while maintaining financial stability.

SECTION 1 BOARD POLICIES

INTRODUCTION

The Gurnee Park District, hereinafter the “District”, is a separate unit of municipal government, established in 1968, governed by a Board of five elected commissioners, hereinafter the “Board”, who serve without pay. The management and control of business and property of the District shall be vested in the Board of Commissioners as created and established by State law.

It is the purpose of the District to effectively and economically provide recreational programs, facilities, and open space for the residents of the District which are designed to provide wholesome, constructive, and enjoyable leisure time experiences that benefit the individual, the family, and the community. The Board acts as the legislative and policy making body of the District in the operation, control, improvement, and planning of its parks, recreation programs, facilities, personnel and fiscal operations.

The Gurnee Park District Board of Commissioners recognizes the need for a manual that contains Board approved policies that facilitate the operation of the District on a day-to-day basis. The Board has reviewed and approved this manual and will in the future periodically review and revise the policies contained in this manual as it deems appropriate.

A. By-Laws and Legal Authority of the Park District

The Park District is governed by numerous statutes of the State of Illinois, (Ill. Compiled Stats.). The principal authority is the Park District Code (70 ILCS 1205/et seq.), which is a codification of the general law relating to park districts in Illinois. References and excerpts from the Park District Code and other related laws may be made in this manual.

B. Legal Authority of this Policy Manual

The authority of the Manual is Section 1205/8-1(d) of The Park District Code, which states as follows:

“(d) To pass all necessary ordinances, rules and regulations for the proper management and conduct of business of the Board and district and to establish by ordinance all needful rules and regulations for the government and protection of parks, boulevards and driveways and other property under its jurisdiction, and to effect the objects for which such districts are formed.”

The statutes of the State of Illinois, of any final court decision that is in conflict with the provisions of this Manual, shall supersede the provisions of the manual.

C. Separability

If any policy or part thereof contained in this manual shall be determined invalid in a court of law, such determination shall not affect the validity of the remaining policies or parts thereof.

D. Defining Policies and Procedures

Policy - A policy is any plan or course of action reflecting the mission to be achieved and officially approved by the Gurnee Park District Board of Commissioners. Policies provide guidance for the operation of the District and give direction to the Board and staff in the discharge of their duties.

A policy must be approved by the Board and recorded in writing.

Procedure – A procedure is any plan or course of action formulated, developed and implemented by the District to facilitate day-to-day operations within the respective policy guidelines. Procedures guide the staff in providing safe, efficient and enjoyable recreational experiences for the public by detailing the specific course of action to be taken within the general framework of the policy.

The Executive Director shall have the responsibility of specifying the procedures under which the Park District operates. These procedures shall govern the day-to-day operations of the District and will, in every respect, be consistent with the policies adopted by the Board.

Procedures will be documented and placed in the appropriate Departmental Procedure Manual.

GURNEE PARK DISTRICT POLICY MANUAL

1.1 Board Membership

1.1.1 Number of Commissioners

The Board shall be comprised of five (5) members.

1.1.2 Term of Office

Commissioners shall be elected to serve for a term of four (4) years. Terms are designed to expire biennially on a staggered system. Commissioners shall serve until their successors are duly elected and qualified.

1.1.3 Qualification

Any person who is a legal voter and who resides within the District for one year prior to the election is qualified to be a candidate for the office of commissioner.

A person is not eligible to serve as park commissioner if that person is in arrears in the payment of a tax or other indebtedness due to the park district or has been convicted in any court located in the United States of any infamous crime, bribery, perjury, or other felony.

1.1.4 Nomination

- A. A candidate for the office of commissioner must file a nominating petition with the Secretary of the District signed by qualified voters of the District, equal in number to no fewer than 2% of the number who voted at the last preceding election for commissioners in the District but in no case by fewer than 25 voters. Illinois Park District Code 70ILCS, hereinafter the "Code".
- B. The Secretary of the District shall make available nominating petition forms and the required number of signatures to any prospective candidate for the office of commissioner and shall publicize the first and last day for filing such nominating petitions well in advance of those dates.

1.1.5 Election

Commissioners shall be elected biennially to take the place of those whose terms expire. Such elections shall take place at the election provided for by the general election law (Illinois Compiled Statutes, (10ILCS 5/1.1 et seq.).

1.1.6 Meeting Attendance

While it may not be possible for every Commissioner to attend every Board meeting, a recurrent pattern of missing meetings is not fair to the other Board members or to the taxpayers. Thus, the Board may declare the office of any Commissioner vacant if that Commissioner fails or neglects to attend any regular and special meetings of the Board for a period of three consecutive months or six regular or special meetings of the Board in any twelve month period.

GURNEE PARK DISTRICT POLICY MANUAL

1.1.7 Vacancy

A. Declaring a Vacancy

If a member of the Board becomes unable to serve due to death, resignation, mental or physical disability, conviction of a disqualifying crime, change of residence outside the District, or for any other reason specified by law (70 ILCS 1205/2-25), the Board may declare the office vacant. If the Board is uncertain about the vacancy, the Board shall conduct a hearing before the vacancy is declared. The Board shall publish in a newspaper of general circulation in the District the notice of such hearing. The Board shall also send a letter registered return receipt requested to the last known address of the Board member whose vacancy is being determined. A resignation of a Board member effective either immediately or at a specific future date may not be withdrawn after it is received by or filed with the Board.

B. Method of Filling Vacancies

Vacancies shall be filled by appointment by a majority of the remaining members of the Board. Any person so appointed shall hold the office until the next regular election at which time a qualified candidate shall be elected to fill the vacancy of the unexpired term.

If a vacancy occurs with less than 28 months remaining in the term, the person appointed to fill the vacancy shall hold office until the expiration of the term for which they have been appointed and no election must be held. If the vacancy occurs with more than 28 months left in the term, but less than 123 days before the next regularly scheduled election for Board members, the person appointed to fill the vacancy shall hold office until the second regularly scheduled election for the office following the appointment, at which a member must be elected to fill the vacancy for the unexpired term. (70 ILCS 1205/2-25)

1.1.8 Prospective Candidate Information Packet

As directed by the Board, staff should prepare a prospective candidate information packet. The packet will be available to any certified candidate upon request. The packet should include essential information about the park district to include, at a minimum, a Board policy manual, a procedures manual, annual budget and an organizational chart. A meeting schedule, brochures and information about any advisory group(s) should also be included.

1.1.9 Inauguration of Board Members

A. Newly Elected or Re-elected Commissioners

Newly elected or re-elected Commissioners shall be inaugurated (sworn-in) at the annual meeting held on the next regular meeting following the certification of election results by Lake County.. At this time, the “old” Board shall meet and conduct any unfinished business. The Secretary of the District shall then inaugurate the newly elected Commissioners and the re-elected Board members and then adjourn the meeting sine die. The new Board shall then convene the annual meeting.

GURNEE PARK DISTRICT POLICY MANUAL

B. Appointed Commissioners

Newly appointed Commissioners shall be inaugurated at the first regular Board meeting following their appointment.

C. Board Member Orientation

Newly elected Commissioners will be provided a Board Member Orientation Manual. The orientation should be conducted as soon as possible after inauguration. The manual will include, at a minimum, a Board policy manual, a procedures manual, annual budget, phone lists and organizational chart. Newly elected Commissioners will provide evidence of receipt of the orientation manual through written confirmation.

1.1.10 Commissioner Privileges

A. Compensation

Board members shall act as such without compensation. (70 ILCS 1205/4-1)

B. Conferences and Seminars

Opportunities to attend and participate in professional conferences, conventions, workshops, seminars, and technical meetings shall be provided at District expense subject to budgetary provisions. Reimbursable expenses shall include registration fees, transportation, lodging, meals, and other legitimate expenses. Approval of expenses for travel and training will comply with Board policy 3.14, adopted pursuant to the Local Government Travel Expense Control Act (50 ILCS 150/1, et seq.).

C. Professional Associations

The District shall establish membership in and pay dues for Board members to the National Recreation and Park Association and the Illinois Association of Park Districts or any other professional association approved by the Board. Because both the National Recreation and Park Association (NRPA) and the Illinois Association of Park Districts (IAPD) serve the educational, legislative and research needs of the Board, which subsequently benefit the District, and because members of the NRPA and IAPD Boards of Directors and committees are drawn from commissioners from throughout the nation and state, the Board encourages its members to serve on the Boards and committees of NRPA and IAPD and shall reimburse any and all usual and customary expenses incurred by Board members which are directly related to their involvement with NRPA and IAPD Boards or committees.

D. Community Relations Activities

The Board of Commissioners supports the District's representation at non-political social events within the community and surrounding area. The Commissioners, the Executive Director and others designated by the Board are authorized to attend social events for the purpose of increasing the District's involvement in the community and furthering the mission of the District. The District shall pay the fee charged for participation in a non-political social event by the Commissioners, Executive Director, and other District employees, as approved by the majority of the Board and/or the Executive Director.

GURNEE PARK DISTRICT POLICY MANUAL

E. District Programs and Facilities

The Park Board determined (Ordinance #06/07-3) that because it is necessary for the faithful execution of their duties to attend, participate in and get feedback from the users and patrons of the District's facilities and programs, it is in the best interest of the District and its residents to allow Commissioners a program fee discount while exercising their duty to manage and control all of the District's property and to plan, establish and maintain recreational programs.

Therefore, while in office, Commissioners are entitled to:

- 1) Free entrance to any of the District's facilities for the purposes of observation and evaluation.
- 2) The Park District offers Commissioners in office a program discount benefit similar to that offered to part time employees. (See GPD Personnel Policy Appendix G). It is advantageous for Commissioners to attend various recreation programs and give feedback to the staff. In an effort to lessen the financial burden it may create for the Commissioners; the program discount was instituted. Since some programs can only be experienced through the participation of family members, e.g. youth soccer, dance, etc. the program fee discount extends to members of the commissioner's immediate family living in the same household who qualify as dependents under the IRS definition. These benefits are intended for Park District Commissioners' personal use only and do not apply to groups, organizations or clubs that the Commissioners may be associated with.

F. Indemnification

To the extent allowed by law, Board members shall be indemnified against claims and actions and shall be insured against any liability asserted against them in the performance of their duties as members of the Board.

G. Additional Costs

Any additional items such as travel, supplies or equipment required for any particular program would be the responsibility of the Commissioner, Commissioner's spouse or dependent children.

GURNEE PARK DISTRICT POLICY MANUAL

1.2 Ethics and Conduct

1.2.1 Ethics Act

Commissioners must file a statement of economic interests, pursuant to the Illinois Governmental Ethics Act, with the County Clerk of Lake County (5 ILCS 420/1-101 et seq.).

1.2.2 Legal Authority

The Board, as a whole, is the legal corporate authority of the District. As an individual, a Board member has no legal authority to determine policy, give directions to District personnel, or to act or speak for the Board unless specifically authorized to do so by official Board action.

1.2.3 Representation

Board members represent all of the residents of the District and should avoid representing special interest groups. Board members should also avoid making public promises or statements regarding their votes or position on an issue prior to an official meeting.

1.2.4 Code of Conduct

The Gurnee Park District Board recognizes the need for decision-making and public responsiveness, which requires a commitment to ethical, business-like and lawful conduct including proper use of authority and appropriate decorum when acting as a Board member. Accordingly, Board Members will:

- 1) When outside of Board meetings, avoid making individual pronouncements and public conjectures about agency matters not yet decided by the Board.
- 2) Represent all the people of the community while avoiding partisanship based on special interests.
- 3) Engage in no self-dealing or the conduct of any private business or personal services between any Board member and the organization except as procedurally controlled to assure openness, competitive opportunity and equal access to “inside” information.
- 4) Recuse themselves from discussing or voting on an issue about which they have an unavoidable conflict of interest.
- 5) Not promise in advance of a meeting how they will vote on any issue, reserving judgment until all facts have been presented.
- 6) Not use their position to obtain employment for themselves, for family members or close associates. (Should a member desire employment, they must first resign.)
- 7) Make decisions involving the welfare of the agency based on study and evidence, recognizing that personal feelings, opinions and other such factors are not conducive to sound decision-making; and understand that respecting the opinions of fellow Board members is vital.

GURNEE PARK DISTRICT POLICY MANUAL

- 8) Accept the principle of Board unity by supporting majority decisions of the Board.
- 9) Respect the Board's commitment to work with the Executive Director by:
 - a. requesting desired information about the agency's programs directly from the Executive Director,
 - b. referring to the Executive Director's suggestions for new policies,
 - c. seeking the Executive Director's professional advice,
 - d. refraining from acting on any complaint until after the Executive Director has had an opportunity to investigate fully and report to the Board, and
 - e. wholeheartedly supporting Board-approved actions of the Executive Director and the staff.
- 10) Recognize that the individual Board member has no more authority over agency policies or operations and shall speak or act for the Board only when specifically authorized to do so by action of the Board.
- 11) Understand and respect the separation of Board responsibilities and functions from those of the Executive and staff. The Board's responsibility is to ensure that the agency is well managed — not to manage the agency.
- 12) Consider it unethical and thus avoid "secret" sessions of the Board held without the presence of the Executive Director.
- 13) Respect the confidentiality appropriate to issues of a sensitive nature.
- 14) Commit to regular attendance at Board meetings and be properly prepared for Board deliberation.
- 15) Understand and follow all provisions of the Illinois Open Meetings Act, as well as any other applicable statutes that govern the conduct of elected officials.
- 16) Participate in community activities.
- 17) Participate in Board development opportunities.
- 18) Develop productive relationships with other elected officials at the state, local and national levels.
- 19) Be available and responsive to residents by interpreting the needs of citizens to the agency and by interpreting the actions of the agency to citizens without favor of any particular geographic area or interest group.
- 20) Keep the best interests of the District in mind by considering themselves a "trustee" of the District and doing their best to ensure that it is well maintained, financially secure, growing and always operating in the best interests of those the agency serves.
- 21) Respect, listen and communicate with fellow Board members and the Executive Director.

GURNEE PARK DISTRICT POLICY MANUAL

- 22) Make a committed effort to continuing education and to be well informed about issues and trends that could affect the agency.
- 23) Review Board packet materials prior to arriving at Board meetings so as to be prepared to participate in the discussion and vote on all matters listed on the agenda.

1.2.5 Gift Ban Law

Board members (as well as employees) are responsible for understanding and adhering to the State of Illinois Gift Ban Law.

- A. Public officials should not accept gifts in types and amounts which will improperly influence their decisions. The Ethics Law affects elected or appointed officers, all employees including contractual employees, spouses or immediate family members living with the officer or employee.
- B. Park District officers or staff members (or immediate family) cannot intentionally ask for or accept any gift from a “prohibited source”. A prohibited source is any person or entity that:
 - 1) Wants the Park District officer or employee to take some kind of official action on their behalf or to get the employee’s supervisor to do so.
 - 2) Does business with the Park District or hopes to do business with the Park District in the future.
 - 3) Conducts activities that are regulated by the Park District official or employee.
 - 4) Has an interest that may be affected in a good or bad way by the performance or non-performance of the Park District official or employee’s official duties.
- C. A “gift” is anything having a monetary value including cash, food or drink. For example, it includes any gratuity (tip), discount, entertainment, or hospitality.
- D. Exceptions to this law are:
 - 1) You may accept food or refreshments not exceeding \$75 per person on a single calendar day provided it is consumed on the premises or catered.
 - 2) Any item or items from any one “prohibited source” during any calendar year that have a total value of less than \$100.
 - 3) Opportunities that are available on the same conditions as the general public.
 - 4) Anything that the officer or employee pays fair market value for.

GURNEE PARK DISTRICT POLICY MANUAL

- 5) Any lawful contribution (under the Election Code) to support a candidate or political organization.
 - 6) Educational materials.
 - 7) Travel expenses for a meeting to discuss business.
 - 8) A gift from a relative.
 - 9) Anything provided to you by a personal friend only on the basis of your friendship.
 - 10) Anything provided to you (e.g. food, lodging, transportation, etc.) because of an outside business or employment activity that you are involved in. It cannot have any connection to your official Park District position.
 - 11) Any gift given by a Park District officer or employee to another Park District officer or employee. (“Intra-governmental gift”)
 - 12) Any gift given by a Park District officer or employee to an officer or employee of another taxing body. (“Inter-governmental gift”)
- E. If you receive a gift that is prohibited under this law, you do not violate the policy if you (or your spouse or immediate family member) make a reasonable attempt to return the gift or give the gift or an amount of equal value to an appropriate charity that is exempt from income tax under Section 501 (c)(3) of the IRS Code. Contemporaneous records describing how a Commissioner has cured a violation should be retained by the Commissioner and filed with the Executive Director.

1.2.6 Prohibition of Political Activities

- A. Illinois law restricts the use of governmental funds and facilities for partisan political purposes. It applies to units of local government and school districts. The law defines “officer” as an elected or appointed official whether the official is compensated or not. “Employee” is defined as full time, part time or contractual. The law states:
- 1) No officer or employee shall perform any ***prohibited political activity*** during the time they are being compensated by the Park District. (work time)
 - 2) No officer or employee can use any property or resource of the Park District for any prohibited political activity.
 - 3) No officer or employee can require any other officer or employee of the District to perform any prohibited political activity as part of that person’s work duties, as a condition of employment, or during paid time off (such as vacation, holidays, etc.).

GURNEE PARK DISTRICT POLICY MANUAL

- 4) No officer or employee can be made to participate in prohibited political activity by being promised additional compensation, salary adjustment, bonus, comp time off, continued employment, etc. No one can be rewarded with additional compensation for participating in a prohibited political activity. Compensated time is any time worked by or credited to an employee that counts as work time required for continued employment.

“Compensated time” does not include vacation, personal or compensatory time off. (Meaning employees are allowed to participate in these “prohibited political activities” during their vacation, personal time, etc.)

B. A prohibited political activity is:

- 1) Preparing for, organizing or participating in a political meeting, rally, demonstration etc.
- 2) Soliciting contributions including selling, distributing or receiving payment for political fundraiser tickets, meetings, etc.
- 3) Soliciting, planning solicitation, or preparing any document regarding anything of value intended as a campaign contribution.
- 4) Planning, conducting, or participating in a public opinion poll in connection with a campaign for office, a political organization or for/against any referendum question.
- 5) Surveying potential or actual voters in an election to determine probable vote outcomes.
- 6) Assisting at the polls on Election Day on behalf of any political candidate, organization or referendum question.
- 7) Soliciting votes on behalf of a candidate, organization, or referendum question or helping to get voters to the polls.
- 8) Initiating for circulation, preparing, circulating or filing a petition on behalf of a candidate, organization or referendum question.
- 9) Making contributions on behalf of any candidate for elective office.

GURNEE PARK DISTRICT POLICY MANUAL

- 10) Preparing or reviewing responses to candidate questionnaires in connection with a campaign for elective office or on behalf of a political organization.
- 11) Distributing, preparing or mailing campaign literature, making signs, etc. for a candidate for elective office or regarding a referendum question.
- 12) Campaigning for office or for or against any referendum question.
- 13) Managing or working on a campaign.
- 14) Serving as a delegate to a political party convention.
- 15) Participating in a recount or challenge to the outcome of any election.

1.2.7 Board Values

The Gurnee Park District Board of Commissioners is committed to provide leadership for the agency in a functional, cohesive, and productive manner. In an effort to attain this, the Board has set the following values:

A. Mutual Respect

The Board shall strive to work together as a team recognizing individual differences. We seek cooperation and consensus building between Board members and staff. We value the opinions of others.

B. Open and Honest Communication

We strive for open, honest, direct communications with ongoing active listening between Board members, staff and community members. The communication will be clear, tactful and timely. Individual differences are accepted, and all subjects are open for discussion.

C. Integrity

The Board shall maintain the trust and respect for each other, the staff, and the community by being accountable, responsible, and keeping commitments.

D. Empowerment

As a team, we believe that we are responsible for our success and let people do their jobs. We will continually foster a work environment built around trust, accountability, follow-through, dignity, self-confidence, and sound decision-making.

GURNEE PARK DISTRICT POLICY MANUAL

E. Vision/Goal/Strategy

The Board shall manage the District and provide leadership based on long term vision created as a team through strategic initiatives and the goals and strategies associated with them. The Board's responsibility is to ensure that the agency is well managed – not to manage the agency.

F. Proactive vs. Reactive

The Board shall take necessary measures to assure that they are being proactive rather than reactive. Make decisions based on the best information available.

G. Professionalism

The Board shall portray a positive image of the Park District at all times while representing the Park District as well as dealing with staff and the community.

H. Non-partisanship

The Board shall represent all people of the community while avoiding partisanship based on special interests. Accept the principle of Board unity by supporting majority decisions of the Board.

I. Motivated and Positive

The Board strives to build self-esteem for fellow Board members as well as staff members by communicating positively. The Board will support each other and the staff to grow and change for the betterment of the Park District and the community.

J. Enjoy being a Board member

Have fun leading the District forward and take pride in the accomplishments.

1.2.8 Communication

Gurnee Park District Board and staff work as a team and the Executive Director will cooperate in every possible way in carrying out the various services provided by the District.

Good communications between the Board and the Executive Director are the keys to a successful operation. In addition to the monthly Board packet, the Executive Director shall keep Commissioners advised of Park District developments, programs and problems that will be helpful in the Board's formulation of policies. Commissioners should have needed accurate information about various Park District activities and problems so that they will know about these matters as they develop, and will be able to discuss them, if approached by our residents. All requests for information will be made to the Executive Director. All Commissioners should be fully and equally informed, therefore any information provided as a response to one Commissioner's request shall be made available to all Commissioners.

GURNEE PARK DISTRICT POLICY MANUAL

Any request for action should be made through the Executive Director. Occasionally a Commissioner may have suggestions on various operating procedures. Often these can be handled by talking with the Executive Director. However, if there is not a consensus agreement, then the matter should be discussed by the Park Board before any changes can be implemented.

1.2.9 Contact with the Media

As a Commissioner, you may be contacted by the news media for your comments. If unfamiliar with the issue, a Commissioner may wish to call the reporter back so that he can be prepared with facts. The Commissioner is encouraged to consult with the Executive Director prior to responding to the media on unfamiliar issues. A Commissioner does not have the ability to speak as an independent citizen on any community issue, related or non-related to the Park District.

1.2.10 Email Communications Policy

It is the goal of the Board of Commissioners of the Gurnee Park District to keep its members as well as the Park District Executive Director informed about matters affecting the Board's work. However, the Board must be aware of the requirements imposed by the Illinois Open Meetings Act, Freedom of Information Act and the Local Records Act, particularly as they apply to communication among Board members outside normal Park District Board meetings.

Generally, Commissioners shall not use e-mail to conduct Park District business. E-mail communication to, by and between Park Commissioners is permitted on a limited basis for non-substantive matters such as:

- Agenda item suggestions;
- Reminders regarding meeting times, dates, and places;
- Board Meeting agenda or public record information concerning agenda items; or
- Responses to questions posed by the community, administration or staff, subject to this policy's first section.

E-mail sent between and among Commissioners regarding such non-substantive matters shall be copied to the Executive Director. There is no expectation of privacy for any messages sent or received by e-mail.

Procedure for Email Communications:

The Board of Commissioners hereby adopts the following procedures with regard to the use of e-mail and similar electronic forms of communication to assist in our efforts to comply with the Open Meetings Act.

1. The electronic "chat rooms" are inherently detrimental to the open meetings process and therefore the Board will not utilize "chat rooms" to conduct Park District business or deliberations.

GURNEE PARK DISTRICT POLICY MANUAL

2. “Bulletin Boards” or other similar formats, which permit the development of “discussion threads” among Board members, also will not be utilized; however, Board members may read the comments of others who are not Board members as they see fit.
3. The Park District Executive Director may provide information relating to Park District business to Board members using e-mail, attachments or other electronic methods. An appropriate record of these communications will be maintained in the District files to assure compliance with open records laws.
4. A Board member may send e-mail items to all other Board members with items of passing interest provided that no response is requested or required. Such e-mails should clearly state that no response should be made. It is required that a copy of any such e-mails be sent to the Executive Director for storage.
5. A Board member may send e-mail items to all other Board members regarding scheduling issues. Board members may reply to the sender provided only that their response is limited to the subject of the original message and does not cross over to items of substance.
6. Commissioners may correspond between themselves if such correspondence would not constitute a violation of the Open Meetings Act. Commissioners may share information if there is no intent to conduct public business.

(Any communication between three Commissioners about substantive Park District business constitutes a violation of the Open Meetings Act. Three Commissioners constitute a quorum of a five-member Board.)

7. Any item of business for a Board agenda shall be directed to the President and the Executive Director so that it may be included in the Board’s agenda according to normal procedures. Action items shall be prepared and distributed by the Park District in accordance with the Board’s established procedures.
8. Commissioners shall not communicate to or with each other by e-mail or text messaging during meetings of the Board.

The Park District shall store official e-mail records. The records shall be maintained for a time period that is established by the State of Illinois.

1.3 Powers and Duties of the Board

The general corporate powers of the Board, as set forth in the Code, include but are not limited to the following responsibilities:

1.3.1 Policies

To study, develop and adopt policies that will satisfy the park and recreational needs of the community and to see that such policies are effectively administered.

1.3.2 Budget

To adopt an annual budget in order to provide the best possible facilities, programs, and services to the public and to establish and enforce controls for the expenditure of funds within the limitations of the budget.

1.3.3 Tax Levy

To annually appropriate funds and levy taxes in order that the District's needs may be met.

1.3.4 Evaluations, Goals and Objectives

To appraise and evaluate the District's recreational programs and services, the physical conditions of the buildings and grounds, and the efficiency of the personnel; and to establish goals and objectives for recreational programs and services, land development, capital expenditures and operations.

1.3.5 Official Actions

The Board functions under the authority of the Illinois Park District Code, the Gurnee Park District "Ordinance Code", and within the framework of laws, court decisions, opinions of the Illinois Attorney General and similar mandates from the state and national levels of government. Board members, collectively and individually, act as representatives of all residents of the District in maintaining and promoting the use of park and recreation activities. Through an evaluation of the available resources and the often conflicting needs and demands of all interested parties and groups, Board members seek to move toward decisions and actions which best serve the recreational needs of the community as a whole.

The Board shall concern itself primarily with broad questions of policy rather than with administrative details. The application of these policies is an administrative task to be performed by the Executive Director and staff who shall be held responsible for the effective administration and supervision of the District including all facilities and programs. All such facilities and programs shall be operated within the financial guidelines determined by the Board.

In the discharge of their duties, Board members act as a Board and not as individuals. The Board functions as a team and issues orders through Board action at meetings. The individual Board members have no more authority over park and recreation policies or personnel than any other citizen. The individual Board member has no legal or moral right to speak for the Board unless specifically authorized to do so by action of the Board. It is improper, ill-advised and unethical for individual Board members to make public

GURNEE PARK DISTRICT POLICY MANUAL

pronouncements and/or conjectures about Board matters either not yet decided by official Board action or decided in a properly called Executive Session of the Board. Board members should respect the Board's commitment to work through its Executive Director. Board members should also seek information from the Executive Director when asked by a resident to address a particular issue or complaint. The Board sets policy, but generally does not get involved in grievances; complaints are politely heard then usually referred to the Executive Director for resolution.

1.3.6 Board/Staff Roles

- A. Board– hires the Executive Director, sets policy, budget and appropriations, and tax levy and determines overall direction of District.
- B. Executive Director - advises Board, administers day-to-day operations, provides leadership of the District, and acts within limits set by Board. (*See also the Governance Memo between the Board and Executive Director.*)

1.4 Officers of the Board

The Board shall elect a President and Vice President from their members at the annual meeting of the Board. The terms of office shall be one year, or until their successors are elected, and shall become effective immediately following their election at the annual meeting. (70 ILCS 1205/4-8).

1.4.1 President

The President shall be executive officer of the Board. The duties of the President shall include but not be limited to presiding at all meetings when present, to sign all contracts and other papers authorized by the Board to see that all ordinances of the Board are enforced and that all orders of the Board are faithfully executed.(Code, 70 ILCS 1205/4-9).

1.4.2 Signature of President and Officers

The President, or in the President's absence or disability, the Vice-President, shall for and on behalf of the District, sign all bonds issued by the District and all warrants drawn against and in anticipation of taxes, provided, however, that said signatures may be executed with a facsimile signature in compliance with the provisions of the "Uniform Facsimile Signature of Public Officials Act," as amended or may hereafter be amended, provided, however that at least one signature required or permitted to be placed thereon shall be manually subscribed. All checks must be signed by two of the following officers: President, Secretary, Treasurer or Executive Director.

1.4.3 Vice President

In the case of the death, resignation, absence from the Gurnee Park District, or other disability of the President, the powers and duties of the office of President, until a successor shall be chosen, or until the disability shall be removed, shall devolve on the Vice-President. The Vice-President shall have such other duties as may be imposed by ordinance or by law.

1.5 Appointed Personnel of the Board

The Board shall appoint a Secretary, a Treasurer, an Attorney, and an Executive Director, prescribe their duties and establish the term of appointment. The Secretary and Treasurer need not be Board members, in which case the Board may fix their compensation. (Park Code, 70 ILCS 1205/4-8).

1.5.1 Secretary

The Secretary shall keep the corporate seal and all books and records pertaining to their office, shall attest and affix the corporate seal to all instruments requiring such action when authorized by ordinance or vote of the Board. The Secretary shall give notice of and attend all meetings of the Board and keep a full and true record of the Board proceedings, including all ordinances passed, supervising elections and referenda within the District, and performing such other duties as usually pertain to the office, as are required by law, or as may be delegated by the Board.

The corporate seal of the District shall be circular in form with the words “Gurnee Park District, Gurnee, Illinois” between concentric rings upon the margin and the words “Corporate Seal” within the inner circle.

1.5.2 Treasurer

- A. The Board shall appoint a Treasurer who does not have to be a member of the Board. The Treasurer shall receive and safely keep all moneys belonging to the District, depositing, in the name of the District, all moneys belonging to the District and received by the Treasurer in the bank or banks approved and designated the Board. The Treasurer is responsible for investment decisions and activities pursuant to the investment policies approved by the Board. The Treasurer shall disburse the same only upon the authority of the Board, together with properly executed warrants.
- B. The Treasurer shall make such reports to the Board of all receipts and disbursements, submitting to the Board, during the first quarter of the fiscal year, a detailed statement showing all receipts and disbursements during the preceding year. Acting under the supervision of the Board, the Treasurer shall have charge of the District's bookkeeping and system of accounts. The Treasurer shall furnish to any Board Member or officer, information on any matter relating to this office, requested by same, including copies of records of receipts and disbursements, statements of account, audits and other records of the District under their control or supervision.

1.5.3 Attorney

The Board shall engage a Park District Attorney, who shall serve at their pleasure. The Attorney shall be the advisor to the Board and for the District in all legal matters and shall be in charge of the prosecution and defense of all litigation in which the District is interested. The duties of the Attorney shall include, but not be limited to, drafting and/or reviewing any ordinances, resolutions and agreements and other instruments required by the Board; giving opinions on all questions referred by the Board; and performing such

GURNEE PARK DISTRICT POLICY MANUAL

other legal duties as are required by the Board. The Board may annually review the compensation and working agreements of the Attorney.

1.5.4 Executive Director

A. The Executive Director shall be the chief administrative officer of and professional advisor to the District. The Executive Director shall supervise the administration of the District, including:

- 1) develop, interpret and promote the recreation philosophies of the District;
- 2) implement Board decisions and policies;
- 3) communicate with all Board members on matters of importance;
- 4) prepare agenda and supportive written reports and studies for regular and special Board meetings;
- 5) recommend and implement administrative improvements and efficiency measures;
- 6) develop agency goals and objectives annual report and monitor monthly;
- 7) analyze and handle crisis situations, delegating authority as necessary;
- 8) review and recommend changes in the District's Policy and Procedure Manual and the District's Personnel Policies;
- 9) develop strategy to prepare and implement projects and programs; and
- 10) approve new recreation programs.

B. The Executive Director shall supervise public relations activities of the District, including:

- 1) demonstrate an understanding of local social, service and political entities;
- 2) coordinate and direct all information released in the name of the District;
- 3) serve as the spokesperson for the District at public meetings;
- 4) maintain positive press relations;
- 5) respond to citizen complaints and inquiries within five working days of receipt;
- 6) serve as liaison to Citizen Advisory Committees;
- 7) develop positive relationships and interchange ideas with other park districts; and
- 8) maintain a continuing cooperative relationship with various civic, school and municipal Boards and administrators within the community.

C. The Executive Director shall supervise the financial planning and management of the District, including:

- 1) coordinate the annual budget preparation;
- 2) recommend the philosophy and guidelines for the annual tax levy;
- 3) monitor the monthly Budget Comparison Report and recommend alterations to the budget when necessary;
- 4) submit special reports on financial status of facilities and programs;
- 5) recommend cost containment procedures aimed at maximizing available resources;

GURNEE PARK DISTRICT POLICY MANUAL

- 6) develop and annually update a multi-year capital improvement plan;
 - 7) determine priorities of capital items;
 - 8) set fees for District programs and facilities; and
 - 9) enter into contracts not exceeding the legal threshold for contracts which must be let by competitive bidding, regardless of whether such contract is actually awarded by competitive bids.
- D. The Executive Director shall supervise the management of personnel, including:
- 1) determine annual staffing patterns and recruit, employ, terminate, lay off and discipline employees;
 - 2) recruit, employ and train department heads;
 - 3) work with the District's attorney on matters requiring legal review and interpretation;
 - 4) conduct written performance appraisals on all department heads on a timely basis;
 - 5) conduct staff meetings with department heads on a timely basis;
 - 6) create new full time or shared positions; approve job descriptions, grant merit raises and recommend salary pool increase amount and salary range adjustments; recommend changes to the employee fringe benefit package;
 - 7) conduct quarterly staff development training programs for all administrative/supervisory personnel; and
 - 8) administer employee surveys to determine opinions on attitudes and working conditions and implement action plans for improvements.
 - 9) Discipline employees, up to and including termination.
- E. Exercise exclusively any powers, duties or responsibilities conferred upon the Executive Director in any District contract or other instrument, or resolution, executed or adopted on or before the date of enactment of this section;
- F. Exercise such power to purchase and enter into contracts as provided in the Ordinance Code; and
- G. such other duties and responsibilities as required by law, or ordinance and be subject to such other rules and regulations as the Board may from time to time prescribe.

The Executive Director may delegate authority but shall nevertheless be responsible to the Board. The Board shall perform an annual written evaluation of the Executive Director or more often as may be deemed necessary.

1.5.5 Additional Duties

In addition to the duties herein specified, each officer and employee shall perform such other duties as may be required by the Board or by law.

1.5.6 Compensation

GURNEE PARK DISTRICT POLICY MANUAL

The officers who are not members of the Board, and all employees shall receive such compensation for their services as the Board shall from time to time determine.

1.5.7 Removal

Any employees or officers chosen by the Board may be removed by the Board whenever in its judgment the best interests of the District would be served thereby. Any employee hired by the Executive Director may be removed by the Executive Director whenever the Executive Director determines that such removal is in the best interests of the District.

1.6 Committees of the Board

A. Special Committees

1) Board Committees

The President of the Board may, from time to time, appoint, by and with the consent of the Board, special Board committees as the need arises.

2) Citizen Advisory Committees

The President of the Board may, from time to time, appoint, by and with the consent of the Board, special committees from District residents for the purpose of studying specific problems of the District, and affording help and assistance in the District's major undertakings.

B. Open Meetings

All official meetings of the committees duly appointed by the Board are subject to the rules and regulations set forth in the Open Meetings Act (5 ILCS 120/2 et. seq.) and rules established by the Board and shall be scheduled, conducted, and recorded accordingly.

1.7 Board Meetings

1.7.1 Open Meetings Act

All official meetings of the Board are subject to the rules and regulations set forth in the Open Meetings Act (5 ILCS 120/2 et seq.) and rules established by the Board and shall be scheduled, conducted, and recorded accordingly. It is improper for a quorum (3 members) to gather to discuss District business without public notice given in accordance with the Open Meetings Act.

The Open Meetings Act has defined “meeting” to mean “any gathering, whether in person or by video or audio conference, telephone call, electronic means (such as email, chat rooms and instant messaging) or other means of contemporaneous interactive communication, of a quorum of the members of a public body held for the purpose of discussing public business.”

Three members of the body constitute a quorum and the affirmative vote of three members is necessary to adopt any motion, resolution, or ordinance, unless a greater number is otherwise required. This makes every abstention a vote that does not fall with the majority.

1.7.2 Annual Meeting

The annual meeting of the Board shall be held on the third Tuesday of May in each year at 7:00p.m. This shall be the organizational meeting of the Board where the new commissioners shall be inaugurated, the President and Vice President shall be elected, and the Secretary and Treasurer shall be appointed. Other business may be transacted at this meeting.

1.7.3 Regular Meetings

The regular meetings of the Board shall be held on the third Tuesday in each month of the year at the hour of 7:00 p.m., unless another day or time shall be specified in the annual meeting schedule adopted each year. An agenda shall be posted at least forty-eight (48) hours before each regular meeting or as otherwise required by state law. Any regular meeting falling on a legal holiday shall be held on the next following secular day at the same hour and place. The Board may, from time to time, change the day/date of a meeting. The Board will review and approve the meeting calendar annually.

1.7.4 Special Meetings

Special meetings of the Board may be called by the President on their own motion or on request of two or more Board members. Notice of any such special meetings shall be given as required by the Open Meetings Act (5 ILCS 120/2 et seq.).

Special meetings may be called pursuant to state law. All Board members shall provide to the District an address at which all notices may be delivered. The notice shall be delivered to each member of the Board electronically or personally if possible, and if not possible, a copy of such notice shall be left at the home or at such other address as is provided by the Board member.

GURNEE PARK DISTRICT POLICY MANUAL

1.7.5 Place of Meeting

Board meetings shall normally be held at the Viking Park Community Center, 4374 Old Grand Ave., Gurnee, IL. However, the Board may, from time to time, change the place of any such meeting.

1.7.6 Public Meetings

A. Open Meetings

All meetings of the Board shall be open meetings and shall be held in accordance with the Open Meetings Act (5 ILCS 120/2 et seq.)

B. Closed Meetings (Executive Session)

The Board may hold a meeting closed to the public or close a portion of a meeting to the public for reasons which include but are not limited to discussion of personnel, land acquisition, litigation, or the review of closed meeting minutes. Any such closed meeting shall be held in accordance with the Open Meetings Act (5 ILCS 120/2 et seq.). No final action on any Board matter may be taken at a closed meeting.

Closed meetings must be recorded and the audio tapes held for 18 months. Verbatim recordings of closed session meetings may be destroyed if, (a) the minutes of such closed session meeting have been approved by the Board, and (b) more than eighteen (18) months have transpired since such meeting.

Executive session minutes that have been held closed are reviewed every six months (in February and August) to determine whether they still require confidential treatment or if they can be released to the public.

C. Emergency Meetings

In the case of a bona fide emergency, a meeting may be called upon such notice as is practicable. The meeting may be called by the President or as otherwise provided by law. The convening authority shall notify all other members of the Board and members of the media who are entitled to such notice.

1.7.7 Schedule and Notice of Meetings

The schedule and public notice of all regular, rescheduled, or reconvened Board meetings for each calendar year shall be posted in accordance with the Open Meetings Act (5 ILCS 120/2 et seq.).

1.7.8 Placing an Item on an Agenda

If a Commissioner would like an item placed on the agenda for discussion, speak to the Board President ahead of time.

GURNEE PARK DISTRICT POLICY MANUAL

In order to provide sufficient advance notice to the public, while the Board can consider any matter not specifically set forth in its agenda at a regular meeting, it cannot act upon that matter.

Items discussed in executive session sometimes are voted upon after returning to open session. Under the Open Meetings Act, those items should be specifically listed on the agenda after executive session in order to take action upon them. (*4th Dist. Illinois Appellate Court decision*)

1.7.9 Quorum

Three members of the Board shall constitute a quorum for each Board meeting and for the transaction of business. The affirmative vote of at least three members is required to approve any Board action.

1.7.10 Convening the Meeting

Each meeting of the Board shall convene at the time appointed for such meeting. The Secretary shall thereupon immediately call the roll of members. If no quorum is present, the Board shall not thereby stand adjourned, but the members present shall be competent, by majority vote, to adjourn or recess the Board to another time or date prior to the next regularly scheduled meeting. If no quorum is present and the members present desire to compel the attendance of absent members, they themselves, or by their agents, shall attempt to communicate the call to the session personally to the absentees.

1.7.11 Order of Business

The order of business shall be as follows, unless a change in the order is necessary for the convenience of the Board or the staff:

- A. Pledge of allegiance;
- B. Roll call;
- C. Minutes;
- D. Bills and payout requests;
- E. Financial report (budget summary);
- F. Treasurer's report;
- G. Visitors' comments;
- H. Director Reports;
- I. Executive Director's report;
- J. Action items;
- K. Other business;
- L. Executive session;
- M. Adjournment.

1.7.12 Remote Attendance at Meetings

A Board member may attend an open or closed meeting from a remote location if the member meets the following conditions and a majority of a quorum of the Park Board votes to approve the remote attendance:

GURNEE PARK DISTRICT POLICY MANUAL

- A. The member must notify the recording secretary at least 24 hours prior to the meeting unless advance notice is impractical;
- B. The member must meet one of four reasons as to why that member is unable to physically attend the meeting:
 - a. because of personal illness or disability
 - b. due to employment purposes or the business of the Gurnee Park District
 - c. because of a family or other emergency
 - d. because of an unexpected childcare obligation
- C. A quorum of the Board must be physically present.

1.7.13 Agenda

The agenda for each Board meeting shall be determined by the President and Executive Director of the District and submitted to the Board *at least 48 hours* in advance of the meeting. The agenda will include allowance for public input. The agenda must be posted in accordance with the Open Meetings Act (5 ILCS 120/2 et seq.).

1.7.14 Board Packet Delivery

The Board packet is emailed to Board members, normally the Thursday prior to the regular Board meeting.

1.7.15 Newspaper Coverage

The Daily Herald, News Sun, Chicago Tribune and Lake County Journal all receive press packets through email prior to the Board meeting. The press packet consists of the agenda, regular meeting minutes, department reports and the executive director's report.

1.7.16 Citizen Participation

Except during the time allotted for public discussion and comment, no person other than a member of the Board shall address that body, except with the consent of the presiding officer. The Board shall afford members of the public time to comment at its meetings. Comments shall be restricted to District business only. The Board needs to conduct its business in an orderly and efficient manner. Therefore, members of the public may address the Board for a maximum of three (3) minutes per person. No person shall address the Board more than once. The total public comment portion of the Board meeting shall not extend beyond thirty (30) minutes. The President, or the presiding officer acting in their place, shall be responsible for the orderly conduct of the meeting. That person shall rule on the appropriateness of remarks, made to the Board. Remarks which are personally abusive to Board members, District staff or District participants will not be allowed.

1.7.17 Discussion

All discussion before the Board shall be with the entire Board and in a voice audible throughout the meeting room. The President shall limit the discussion to matters pending before the Board and may suggest time limitations on discussion.

GURNEE PARK DISTRICT POLICY MANUAL

1.7.18 Deferment of New Business

Upon the majority vote of the members present, any report of a committee of the Board shall be deferred (for final action thereon) to the next regular meeting of the Board after the report is made.

1.7.19 Debate

No member shall speak more than once on the same question; provided, however, that the maker of a motion of the matter under consideration or the chairman of the committee whose report is under consideration, as the case may be, shall have the right to open and close debate. No member shall speak longer than ten (10) minutes at any one time, except by consent of the Board; and in closing debate on any question, as above provided, the speaker shall be limited to five (5) minutes, except by special consent of the Board.

1.7.20 Call of Member to Order

A member when called to order by the presiding officer shall thereupon discontinue speaking, and the order of ruling by the presiding officer shall be binding and conclusive, subject only to right of appeal.

1.7.21 Appeals from Decisions of the Presiding Officer

Any member may appeal to the Board from a ruling of the presiding officer and, if the appeal is seconded, the member making the appeal may briefly state their reason for the same, and the presiding officer may briefly explain their ruling; but there shall be no debate on the appeal, and no other member shall participate in the discussion. The presiding officer shall then put the question, "Shall the decision of the presiding officer be sustained?" If a majority of the members present vote "No" the decision of the presiding officer shall be overruled; otherwise, it shall be sustained.

1.7.22 Question of Personal Privilege

The right of a member to address the Board on question of personal privilege shall be limited to cases in which his/her integrity, character, or motives are assailed, questioned, or impugned.

1.7.23 Voting

Every member who shall be present when a question is stated from the presiding officer shall vote thereon or abstain at the time that their name is first called. A failure to vote shall be counted as an abstention and will count in the manner established by law. Any member required to abstain on a matter due to conflict of interest shall so declare and his/her vote shall not be counted with the majority. Unless otherwise provided by a particular rule of these Rules and Order and Procedure or by state law, passage of any question called for a vote by the presiding officer shall require the affirmative vote of a three of the Board

GURNEE PARK DISTRICT POLICY MANUAL

members. The Board members shall be entitled to cast one vote on each question called by the presiding officer.

1.7.24 Seconding of Motions Required; Written Motions-Reading of Motions, Resolutions, Ordinances, Minutes and Correspondence

No motion shall be put or debated by the Board unless it be seconded, provided, however, that neither the maker nor seconder of a motion shall be required to vote in favor of that motion.

When a motion is seconded, it shall be stated by the presiding officer before debate, and every motion before the Board except motions of procedure, shall be reduced to writing, if required by the presiding officer, and the member who proposed the motion shall be entitled to the floor.

No resolution, ordinance, or minutes need be read aloud prior to consideration, but such items may be read in response to a motion seeking such reading passed by a majority vote of all the members.

Copies of correspondence received by the Executive Director shall be available before the meeting to all members of the Board. Such correspondence need not be read in full at Board meetings unless pertinent to a matter before discussion. Correspondence received may be summarized at Board meetings.

1.7.25 Voice Vote vs. Roll Call Vote

Roll Call vote is used –

- to clarify any vote,
- to go into executive session,
- to approve a consent agenda,
- to approve any expenditure of funds or creation of liabilities, and to pass any ordinance.

1.7.26 Withdrawal of Motions

If the maker of the motion desires to withdraw the motion, he/she may do so. The seconder of the motion may renew the motion as its maker and seek a new seconder. If the seconder of a motion wishes to withdraw their second, they may do so. The maker of the motion may seek additional seconder before the motion is ruled out of order for lack of a second. Neither the maker nor seconder of a motion may withdraw the motion, except with the consent of a majority of the Board, once discussion on the motion has ceased.

1.7.27 Tabling

A motion to lay on the table applies only to the particular proposition currently before the Board. A motion to table an amendment to a main proposition is in order prior to the vote on the main proposition. A motion to table shall be adopted if approved by a majority vote.

GURNEE PARK DISTRICT POLICY MANUAL

1.7.29 When and How to Make a Motion or Second

- A. A motion is a proposal that the assembly take certain action or express itself as holding certain views. A member makes a motion by obtaining the floor and stating, "I move that..."
- B. Seconding motions – A second allows the motion to be discussed and voted on. A member seconds a motion by stating, "second" after the motion has been made.

1.7.30 When to Abstain from Voting

It is a general rule that no one can vote on a question in which they have a direct personal or pecuniary interest (however, it does not prevent a member from voting for self for any office). A commissioner should explain why they are recusing themselves prior to a motion being made or discussion and once that declaration is made, they must remain silent including abstaining from discussion.

1.7.31 Taking and Entering the Votes; Explanation of the Votes

The "yeas" and "nays" on any question shall be taken and entered in the minutes. When the Secretary has commenced to call the roll of the Board, before the taking of a vote by "yeas" and "nays", all debate on the question before the Board shall be deemed concluded, and members shall respond to the calling of their name by the Secretary by answering "yea" or "nay" or "abstain" as the case may be.

1.7.32 Announcement and Changes of Votes

The result of all votes by "yeas" and "nays" shall be announced by the Secretary, and no vote shall be changed after the vote has been announced unless agreed to by all other members present.

1.7.33 Precedence of Motions

The Board shall follow Robert's *Rules of Order* in setting the order of precedence for all motions.

1.7.34 Motion to Refer

A motion to refer to a standing committee shall take precedence over a similar motion to refer to a special committee.

1.7.35 Motion to Amend

A motion to amend a motion or an amendment to a motion shall be in order, but one to amend an amendment shall not be entertained. An amendment modifying the intention of a motion shall be in order, but an amendment relating to a different subject shall not be in order. An amendment to the main question or other pending question may be referred to a committee by the presiding officer, and neither the main question nor such other pending question shall be affected thereby.

GURNEE PARK DISTRICT POLICY MANUAL

1.7.36 Minutes of Meetings

The Secretary of the District shall keep written minutes of all Board meetings as specified by the Open Meetings Act (5 ILCS 120/2.06 et seq.). Unofficial minutes of the preceding Board meeting shall be delivered to the Board members at least 48 hours before the next Board meeting.

The unofficial minutes of the Board meetings held in the preceding month shall be approved by the Board at the first monthly meeting and signed by the President of the Board and the Secretary of the District after any required corrections are made. The Secretary's draft of the minutes may be amended to correctly reflect the events that occurred.

Correction of the minutes must be approved by a majority vote. Approved minutes of all Board meetings shall be made available to the public as specified by the Open Meetings Act (5 ILCS 120/2.06 et seq.) and the Freedom of Information Act (Illinois Compiled Statutes, (1 ILCS 140/1 et seq.).

1.7.37 Record of Ordinances

The Secretary shall keep a record in an ordinance book for such purpose of all ordinances passed.

1.7.38 Publication

All ordinances imposing any penalty for a violation thereof shall be published in pamphlet form, in which case the ordinance in its pamphlet form shall be displayed for a reasonable period in a public place, but for not less than ten (10) days.

1.7.39 Time of Taking Effect

No ordinance that must be published to comply with the foregoing section shall go into effect until ten (10) days after it is so published unless a statement of the urgency of the ordinance is contained in it and achieves passage by a two-thirds vote of the members of the Board then holding office. In all other cases, the ordinances shall go into effect upon the passage thereof, as provided by statute, even though the operation of the ordinance may not take effect until a later date.

1.7.40 Rules of Order

Except as otherwise provided in these rules of order and procedure, the rules of parliamentary practice contained in the Twelfth edition of Robert's *Rules of Order* shall govern the Board. Where there is a conflict between Robert's Rules and these rules of order and procedure, these rules of order and procedure or the statutes or laws of the state shall prevail.

1.7.41 Temporary Suspension of Rules; Amendment of Rules

These rules may be temporarily suspended, repealed, altered, or amended by a two-thirds vote of the Board members then holding office.

GURNEE PARK DISTRICT POLICY MANUAL

1.7.42 Duties of the Presiding Officer

The presiding officer shall preserve order and decorum. The presiding officer may speak to points of order in preference to other members and shall decide all questions of order subject to appeal. The presiding officer may speak to matters being considered by the Board without relinquishing the chair. If the presiding officer refuses to allow the members to exercise their right to appeal a decision of the presiding officer, the members may consider and pass on the matter in spite of the presiding officer's failure to grant them an appeal. The presiding officer shall announce the business before the Board in the order in which it is to be acted upon. The presiding officer shall recognize members entitled to the floor in the order in which they are to be recognized. In case of any disturbance or disorderly conduct, the presiding officer shall have the power to require the meeting room to be cleared. The presiding officer shall state and put to vote all questions which arise in the course of proceedings and announce the result of the vote.

1.7.43 Duties of Members

While the presiding officer is putting the questions, no member shall walk across or out of the meeting room. Every member, previous to their speaking, making a motion, or seconding the same, shall address themselves to the presiding officer and say "Mr./Ms./Mx./or no salutation President" and shall not proceed with their remarks until recognized and named by the presiding officer. The member shall confine themselves to the question under debate, avoiding personalities and refraining from impugning the motives of any other member's argument or vote. When two or more members address the presiding officer at the same time, the presiding officer shall name the member who is to speak first. A member may be expelled for disorderly conduct upon a two-thirds majority vote of the remaining members. Such member may not be expelled a second time for the same offense.

SECTION 2 ADMINISTRATION POLICIES

INTRODUCTION

The Gurnee Park District is a municipal corporation duly organized on September 23, 1968, under an Act of the General Assembly of the State of Illinois, governed by a Board of five elected commissioners who serve without pay. The mission of the Park District is “enriching people’s lives by promoting fun and preserving nature”. It is the purpose of the District to effectively and economically provide recreational programs, facilities, and open space for the residents of the District which are designed to provide wholesome, constructive, and enjoyable leisure time experiences that benefit the individual, the family, and the community. The District administration assists the Board in formulating policy and implementing those policies once they are approved by the Board, employs sound management and financial practices, fosters a positive public image for the District, and provides quality park and recreation programs and services for the residents of the District.

Purpose

This administrative policy manual is intended to describe the existing policies of the District as they apply to the administrative management of the District. The Board has reviewed and approved this manual and will periodically review and revise the policies contained in this manual as it deems appropriate.

Administrative Office

The administrative and principal business office of the District is located at the Viking Park Community Center, 4374 Old Grand Avenue, Gurnee, IL 60031.

Official Records

District public records as defined by the Park District Code (70 ILCS 1205 et. seq.), the Local Records Act (50 ILCS 205/1 et seq.), the Freedom of Information Act (1 ILCS 140/1 et seq.), and the Open Meetings Act (5 ILCS 120 et seq.) shall be made available for inspection and copying accordance with the rules and regulations of the above stated laws.

Structure of Authority

The structure of authority reflects the Park District’s mission statement and methods of operation. Please refer to Appendix A for the Organizational Chart.

Park and Facility Use

Philosophy

The District is ever mindful that the public parks and facilities of the community are held in trust by the District for the use and enjoyment of the general public and this use and enjoyment is a valuable right. The First and Fourteenth Amendments to the United States Constitution guarantees to individuals and groups the inalienable right of public assembly and expression and, historically, public parks and facilities have been a forum for such expression; and an orderly assembly, properly administered, is in accord with the rights of the general public and those of District residents. For these reasons, the District intends to make the parks and facilities available for various uses.

Control of Parks

The Board shall have the authority to establish by ordinance all needful rules and regulations for the government and protection of parks, boulevards and driveways, and other property under its jurisdiction (70 ILCS 1205/8-1(d) et seq.) and to prescribe such fines and penalties for the violation of ordinances as it shall deem proper not exceeding \$1,000 for any one offense (70 ILCS 1205/8-1(e) et seq.). Exercising this authority, the Board has adopted, and may from time to time, amend District Ordinances.

All conditions on the use of public parks and facilities owned by the Park District are described in the Park District Ordinance Code regulations related to Permits.

2.1 Use of Viking Park Band Shell Policy

Statement of Purpose

The Gurnee Park District provides entertainment to the community through various special events. The Viking Park Band Shell houses many of the Gurnee Park District outdoor summer concerts. Due to the high demand for the band shell for Park District events, the Executive Director shall be responsible for setting priorities for outside use based upon, but not limited to the residency of participants and the overall impact of the group or organization on the park as well as the established recreational needs of the Park District.

Administration of the Policy

Park District events will have first priority. Village of Gurnee and local taxing bodies will have priority use secondary to the Gurnee Park District events. Taking into consideration the impact on the neighbors and other Park District ordinances, the Executive Director may approve permitted use for Gurnee-based civic, business and/or educational groups as long as the appropriate fees are paid and 50% of those in attendance will be Gurnee Park District residents.

Use of this facility is at the sole discretion of the Park District, in consideration of a variety of factors. No event shall produce noise levels that interfere with or detract from the general enjoyment of the general public in the surrounding area.

2.2 Naming of Parks Policy

Statement of Purpose

It is the responsibility of the Board to select names for new parks, buildings, and facilities (“park property”), or when appropriate, to change the existing name(s) of park property of the District. This statement of policy is intended to define the method of naming or renaming park property and to outline the conditions governing the selection of names.

Administration of the Policy

The naming of community or neighborhood parks will meet one of the following criteria:

- Names of areas, such as the neighborhood where the park is located.
- Major street names surrounding the park site.
- Park features, such as topography, natural assets, the purposes of the park or activities to be held.
- Donations to the District wherein the donor’s name or that of a third party are used.
- Names of former Park Commissioners, Village officials or citizens who have contributed substantial service in the expansion or growth of the Park District.

The following criteria shall prevail in the naming or renaming of parks:

- No park shall be renamed unless the Board casts a unanimous ballot in favor of the re-naming of the park.
- The selected name for a new or re-named park shall require a majority vote of the Board.
- No park shall be renamed that has already been dedicated to an individual who has contributed substantial service in the expansion or growth of the Park District.
- Individual for whom the park is being named must have given 20 years of service to the District as a volunteer, Board Member, Village Official or Park District employee.

2.3 Non-Discrimination Policy

Statement of Purpose

The Americans with Disabilities Act (ADA) was signed into law on July 26, 1990, and went into effect January 26, 1992. The Americans with Disabilities Act was designed to eliminate discrimination against people with disabilities.

The Act is divided into five major areas, including employment, government services (Title II), public transportation, business and telephone service.

Administration of the Policy

The District services, programs, and activities are subject to all applicable laws regarding non-discrimination including the Americans with Disabilities Act (ADA).

The District will make reasonable accommodations to facilitate an individual's participation in programs and activities.

The District requests that when an individual requires a special accommodation to participate in a program or service provided by the District, the individual is urged to call the Park District prior to the activity. Any necessary accommodations can then be discussed with a staff member or the Executive Director.

2.3.1 Accessibility Study and Compliance

The District will periodically perform a self-evaluation of its accessibility for programs, services and facilities. The evaluation will be performed at a maximum every five years or when a District Master Plan is adopted, whichever comes first. Evaluations may also be performed upon request from local or federal governments, the District's Safety Committee and the District's liability insurance company. The evaluation may include staff and community involvement, an ADA Compliance Officer named by the District, a review of job descriptions and an implementation plan.

2.3.2 Accommodations for Use of a Mobility Device

Individuals with mobility disabilities are permitted to use power-driven mobility devices or electronic personal assistance mobility devices as well as wheelchairs and manually powered mobility aids, such as walkers, crutches, canes, braces, or other similar devices designed for use by individuals with mobility disabilities in any indoor or outdoor areas open to pedestrian use. Persons with disabilities should contact the District's ADA Coordinator for more information. (see also full policy that follows)

2.3.3 Accommodations for Service Animals

Program participants, visitors, park or facility users or employees with disabilities may request to have a service animal (i.e. dog or miniature horse) accompany them. The District may impose some restrictions on service animals for safety reasons. Persons with disabilities should contact the District's ADA Coordinator for more information.

GURNEE PARK DISTRICT POLICY MANUAL

Any other requests or comments regarding the Americans with Disabilities Act, in relationship to the District, can be referred to the Executive Director located at the Viking Administrative office. (see also full policy that follows)

2.4 Smoke Free Environment Policy

Statement of Purpose

The District realizes that the issue of smoking within the workplace and public facilities has been of growing national concern. The 1986 Surgeon General's Report on the Health and Consequences of Involuntary Smoking clearly documents that nonsmokers are placed at increased risk for developing disease as the result of exposure to environmental tobacco smoke. In addition, a 1992 report by the Environmental Protection Agency concurs with the Surgeon General's Report.

Therefore, in the best interest of employees, program participants, guests and visitors of the District, and to create a healthy environment in which to work and recreate, tobacco use of any kind, including use of smokeless tobacco products, is prohibited within all buildings, facilities and vehicles owned, leased, or otherwise in the possession or under the control of the Park District, or within 15 feet of facility entrances/exits, windows that open and ventilation intakes.

In addition, tobacco use of any kind, including use of smokeless tobacco products, is prohibited on or within twenty-five (25) feet of any Gurnee Park District playground, sports field, skate park, shelter or structure including the area around the Viking Park summer kitchen, band shell, and at any Gurnee Park District outdoor special event.

Administration of the Policy

The smoke free environment philosophy is outlined in the District Employee Personnel Policy Manual.

The Smoke Free Illinois law, effective January 1, 2008, prohibits smoking within 15 feet of any park district facility entrance. Gurnee Park District Ordinance 11/12-5 establishes limitations on use of tobacco products on park property.

The Gurnee Park District Tobacco Use Ordinance can be enforced by the Gurnee Police.

2.5 Environmental Policy

Statement of Purpose

It is the intent of the District to encourage its residents, employees, and members of the Board to set a high standard of leadership and competency in the promotion of sound environmental practices and lifestyles. The District feels it has an obligation to set an example and assume a leadership role in development and use of procedures, practices, and environmental applications that promote a healthy environment.

Administration of the Policy

The District will achieve their environmental goals through the following practices:

- A. Purchase and use of environmentally safe and sensitive products:
Purchase products for use in facility and park operations which minimize negative environmental impacts, taking into consideration the effects of product production, use, storage and disposal.
- B. Wise use and protection of air, water, soil, and wildlife:
Actively seek and implement ways to conserve and protect water and soil, enhance air quality, limit the production and release of damaging pollutants, and protect wildlife.
- C. Wise use of energy resources:
Actively seek and implement ways to conserve energy resources and investigate methods of applying energy technologies.
- D. Reduction and handling of waste:
Reduce waste production, reuse and recycle materials from facility and park operations, and handle hazardous and all other wastes according to lawful and safe procedures.
- E. Open space planning and preservation:
Protect and restore indigenous natural communities such as grasslands, woodlands, and wetlands and promote the reclamation, acquisition, preservation and management of other open space areas, including green ways and trails.
- F. Environmental education and interpretation:
Provide education and interpretation opportunities for staff and the public which increase appreciation for the natural world and promote environmentally conscious lifestyles, emphasizing selective consumption and low-impact resource use.

2.6 Comprehensive Needs Assessment Policy

Statement of Purpose

The Gurnee Park District must complete a needs assessment study preferably every three to five years, but at least at a minimum of every ten years with interim updating due to population shifts and changing social and economic conditions.

Administration of the Policy

The assessment should be used to establish priorities for future improvements of parks and recreation facilities, programs and services with the community. The assessment should be designed to obtain statistically valid results from households throughout the Gurnee Park District. The assessment shall also be used to establish benchmarking averages for important parks and recreation service areas.

The Comprehensive Assessment shall include:

- A community attitude and interest citizen survey with a minimum of 2,000 random surveys distributed through mail and phone with a minimum of 400 surveys completed. This may be completed internally or with an outside organization.
- Tax information for the past 10 years with comparison to other Lake County Park Districts.
- Fund Balance Comparison for 10 years
- Program Registration and Facility Usage Statistics
- Profile of General Demographic Characteristics for the Village of Gurnee

2.7 Community/Affiliate Group/Intergovernmental Agreement Policy

Statement of Purpose

The Gurnee Park District (hereafter “District”) recognizes that certain organizations exist within the community whose purposes are to serve and enhance recreational opportunities for a specific purpose and group. These organizations are separate and independent from the District and provide for their own leadership, organizational and operational structure. Although the stated missions of the organizations may differ, public investment in public recreational facilities and programs creates a mutually beneficial environment in which to provide quality recreation for all the individuals served by the parties, as well as the general public.

The District recognizes that at times it is in the best interest of the community that the District work with outside organizations in coordinating, integrating and consolidating the planning and provision of recreational facilities and programs when basic functions are compatible and a public benefit may be derived. Through working relationships with outside organizations and joint efforts, each party can contribute to greater public service without relinquishing their separate identities or any of their individual responsibilities.

It is also in the best interest of the Gurnee community to cooperate in the usage of the parks and facilities operated by the Gurnee Park District or other Governmental Agencies. Pursuant to the provisions of Article VII, Section 10, of the Constitution of the State of Illinois of 1970, and the Intergovernmental Cooperation Act, 5 ILCS 220/1 et seq., the Gurnee Park District has the authority to associate and cooperate with governmental agencies within the community. When this occurs, an Intergovernmental Agreement between the two agencies will be drafted and approved by both governing Boards.

Administration of the Policy

To this end, the District is willing to establish a working relationship and cooperative agreement with Governmental Agencies, Community Groups, Affiliates and Sponsored Groups using the following means:

- Intergovernmental Agreements
- Cooperative Agreements with parent-run youth programs
- Program Sponsorship
- Affiliate Group Agreements

2.8 Identity Protection Policy

Statement of Purpose

This policy is enacted in compliance with the Illinois Identity Protection Act, 5 ILCS 179/1 et seq. (the “Act”), which requires all local government agencies to draft and approve an identity-protection policy.

Administration of the Policy

In conformance with the provisions of said Act:

- A. All employees who have access to social security numbers in the course of performing their duties shall be required to attend training on the protection of confidentiality of social security numbers. The training will include instructions on the proper handling of information that contains social security numbers from the time of collection through the destruction of the information.
- B. Only employees who are required to use or handle information or documents that contain social security numbers may access such information or documents.
- C. Any request for social security numbers from individuals shall be done in a manner that allows the social security number to be easily redacted if a document is required to be released as part of a public records request.
- D. Any request for social security numbers from individuals shall include a statement of the purpose or purposes for which the social security number is being collected and used.
- E. A written copy of this policy shall be filed with and maintained on file by the Board of Commissioners of the Gurnee Park District.
- F. This policy shall be made available to any member of the public upon request.
- G. Any amendment to this policy after its initial adoption shall be filed with the Board of Commissioners of the Gurnee Park District and a copy of the amended policy shall be made available to Gurnee Park District employees.

Violation of the provisions of this policy by employees of the Gurnee Park District shall be grounds for discipline up to and including dismissal.

2.9 Sponsorship Policy

Statement of Purpose

Gurnee Park District welcomes and encourages sponsorships that support the programs and services the District provides to the public. All sponsorships shall be consistent with the District's mission, vision and goals and will conform to all ordinances and policies of the District and will not reflect negatively on the District's public image.

A sponsorship is a mutually beneficial business arrangement between the District and a second party, wherein the second party provides cash and/or in-kind services to the District in return for access to the commercial and/or marketing potential associated with the District. Sponsorships may include sponsorship of one or more of the District's services, projects, events, or activities.

Administration of the Policy

It is the policy of Gurnee Park District:

- A. To facilitate sponsorships as an effective means of generating new revenues and alternative resources to help support District facilities and programs.
- B. The benefits of sponsorships to the sponsor vary based on the amount as well as the event they sponsor as specified in Appendix A.
- C. To enter into sponsorship agreements only if deemed in the best interest of the District by the Executive Director, or their designee.
- D. That sponsorships will not result in any loss of District administrative rights, jurisdiction or authority.
- E. Is not applicable to gifts, grants or unsolicited donations in which no benefits are granted to the donor and where no business relationship exists.
- F. Sponsorship policy will not supersede any existing district policies, including, but not limited to:
 - 2.9 Naming of Parks Policy
- G. Advertising in District publications at events, programs or facilities in conjunction with sponsorship agreements may not contain material that:
 - a) Is religious, political, or cultural in nature.
 - b) Promotes tobacco use.
 - c) Advertises alcohol at events or in publications
 - d) Promotes firearms, adult-use, or other businesses deemed inappropriate by the Executive Director or their designee.
 - e) Is false, misleading or deceptive.
 - f) Is libelous.
 - g) Depicts violence and/or anti-social behavior.

GURNEE PARK DISTRICT POLICY MANUAL

- h) Implies or declares an endorsement by the District of any goods, services or activities.

- H. The type, location, size, design, content, and duration of any advertising, advertising display or sponsor recognition must meet all applicable policies and ordinances and is subject to approval and therefore will be specified in the contract, permit or agreement. Additional signage requests require approval of the Executive Director or their designee.

- I. Freestanding billboards are not allowed on District property.

- J. All sponsored products, materials and services require the Executive Director's approval and must meet the specifications and standards used by the District in the purchase of similar materials.

- K. No District employee is required to wear clothing with sponsor logos or advertising as it could imply District endorsement of a product or service.

- L. All proposals for sponsorships must be submitted in writing to the Executive Director or their designee. It will be the responsibility of the Executive Director or designee to track all proposals.

- M. Each project or program that involves solicitation of sponsors should, PRIOR to procurement, create a Sponsorship Plan specific to that project or program that is in line with the Sponsorship Levels. This plan needs to be approved by the Director of Marketing. In addition, sponsorships need separate approval if they exceed specified limits.
 - 1) Up to \$500- The program or project staff may approve this level of agreement, with review by their supervisors and the Director of Marketing. The Director of Marketing shall provide guidance as needed in the development of a sponsorship plan and any contract details. Any supervisor, for the purpose of special events, fairs or programs, should solicit gift certificates, coupons or small in-kind donations.
 - 2) \$501 to \$2,500- The agreement needs approval of the Director of Recreation and Director of Marketing. The Director of Marketing shall develop the sponsorship plan and any contract details.
 - 3) \$2,500- \$20,000- The agreement needs approval of the Executive Director and Director of Marketing. The Executive Director will review the proposal, seek advice from the Board, if appropriate, and make a decision on the proposal.
 - 4) Over \$20,000 – The agreement needs approval of the Board.

2.10 Cooperation with Homeowners Associations Policy

Statement of Purpose

The District understands the importance of residents' enjoyment of their neighborhood park and wants to facilitate use of the park for events. The District will provide a bona fide homeowner association with assistance for one association event each year. A request will be considered on a first-come first-served basis, dependent on Parks department staffing needs and equipment availability.

Administration of the Policy

The event must take place at the neighborhood park. The homeowner association representative will contact the District rental coordinator and complete a special use permit. The rental coordinator will communicate with the Director of Parks and Planning to determine if assistance can be provided. The rental coordinator will respond to the homeowner association and if the event is approved, coordinate the District's help.

Available amenities are: installation of 20 x 30 tent, six trash receptacles, 10 picnic tables, and portable charcoal grill.

The homeowner association must provide proof of liability insurance coverage and liquor liability insurance if the event will include liquor.

The Parks Department personnel will not incur overtime as a result of staffing a homeowner association event.

2.11 Safety Policy

Statement of Purpose

We acknowledge the importance of providing a safe working environment for our employees as well as a safe leisure environment for the public utilizing our parks, facilities and programs.

It is the intention of Gurnee Park District to develop, implement and administer a safety and comprehensive loss control program. In all our assignments; the health and safety of all should be top priority.

Personnel at all levels are directed to make safety a matter of continuing and mutual concern, equal in importance with all other operational considerations. Each Supervisor is responsible for work being performed in a safe manner, inspections conducted on a regular basis, hazards and dangers confronted and accidents investigated.

Administration of the Policy

A Safety Procedure Manual shall be developed and provided to all staff to address the safety-related responsibilities of employees. It is provided as an appendix to this policy manual.

2.12 Employment of Certified and Professionally Trained Staff Policy

Statement of Purpose

The District recognizes the value of professional training and certifications. Certifications from national and state level organizations relevant to positions in the District are highly desirable. The District, in its recruitment and selection of candidates, prefers applicants to possess the appropriate certifications for relevant positions. The District, in its effort to retain certified employees, will make every effort to contribute towards the maintaining of desired certifications of staff through continuing education opportunities.

Administration of the Policy

Each job description shall clearly outline the required degrees, certifications, licenses, etc. for each job position. The person hiring that individual shall obtain proof of required credentials at the time of hire and place in the personnel file.

2.13 Acceptance of Gifts Policy

Statement of Purpose

The Gurnee Park District encourages individuals and entities desiring to make financial contributions to benefit the District programs, activities, parks and facilities, to do so through donations, gifts or bequests. Sponsorship opportunities are also available for those who would like to support a specific program area.

Administration of the Policy

Any form of financial contributions must be made directly to the Gurnee Park District and the acceptance is based on the approval from the Executive Director or from the Board of Park Commissioners.

2.14 Human Rights Policy

Statement of Purpose

This policy outlines District human rights guidelines for Board members, employees, vendors and the public. The District is committed to an environment in which all individuals are treated with respect and dignity. The law and policies of the District prohibit disparate treatment on the basis of race, color, religion, age, national origin, disability, gender, gender identity, sexual orientation, marital status or any other protected characteristics.

Administration of the Policy

Definitions

For purposes of this policy the following words, terms, phrases and their derivatives, shall have the meanings set forth in this section. When not inconsistent with the context, the present tense shall include the future tense; the plural number shall include the singular number; and the singular number shall include the plural number.

"**Age**" means the chronological age of a person.

"**Disability**" means a determinable physical or mental characteristic of a person, including, but not limited to, a determinable physical characteristic which necessitates the person's use of a guide, hearing or support dog, the history of such characteristic, or the perception of such characteristic by the person complained against, which may result from disease, injury, congenital condition of birth or functional disorder and which characteristic:

- a. unrelated to the person's ability to perform the duties of a particular job or position; or
- b. unrelated to a person's ability to utilize and benefit from a place of public accommodation.

"**Marital status**" means the legal status of being married, single, separated, divorced or widowed.

"**National origin**" means the place in which a person or one of their ancestors was born.

"**Place of public accommodation**" means a business, accommodation, refreshment, entertainment, recreation, or transportation facility of any kind, whether licensed or not, whose goods, services, facilities, privileges, advantages or accommodations are extended, offered, sold, or otherwise made available to the public.

"**Religion**" means all aspects of religion observance and practice, as well as belief.

"**Sexual harassment**" means unwelcome sexual advances, requests for sexual favors, and other verbal or physical conduct of a sexual nature when:

- a. submission to such conduct is made either explicitly or implicitly a term or condition of an individual's employment,
- b. submission to or rejection of such conduct by an individual is used as a basis for employment decisions affecting such individual, or

GURNEE PARK DISTRICT POLICY MANUAL

- c. such conduct has the purpose or effect of unreasonably interfering with an individual's work performance or creating an intimidating, hostile, or offensive working environment.

"Unfavorable military discharge" includes discharge from the Armed Forces of the United States, their Reserve components or any National Guard or Naval Militia which are classified as RE-3 or the equivalent thereof, but does not include those characterized as RE-4 or "Dishonorable."

"Unlawful discrimination" means discrimination against a person because of their race, color, religion, gender, gender identity, national origin, ancestry, age, order of protection status, marital status, sexual orientation, physical or mental disability, pregnancy, unfavorable discharge from military services, as those terms are defined in this section. Unlawful discrimination includes sexual harassment and discrimination on the basis of pregnancy, childbirth or related medical condition.

2.14.1 Conduct Prohibited

A. Employment

It shall be a violation of this policy for any officer, employee or contractor to directly or indirectly refuse to hire, employ, classify or upgrade, to bar or to discharge from employment, or otherwise to discriminate against any individual in the terms, conditions or privileges of employment, including compensation, because of unlawful discrimination.

B. Accommodation

It shall be a violation of this policy for any officer, employee, contractor or member of the public to directly or indirectly deny or refuse to another the full and equal enjoyment of the facilities and services of any public place of accommodation owned or operated by the District, because of unlawful discrimination. With respect to access to facilities and services by persons with disabilities, the District shall comply with the regulations promulgated under the Federal Americans with Disabilities Act.

C. Sexual Harassment

It shall be a violation of this policy for any member of the public to engage in sexual harassment of an employee.

2.14.2 Penalties

A. Disciplinary Action

Any employee who violates the provisions of this policy shall be subject to disciplinary action. Any disciplinary action imposed based on a violation of this section shall be appealable according to applicable contracts, statutes and rules.

B. Fines

Any member of the public, officer or contractor who violates the provisions of this policy shall be subject to fine not to exceed \$1,000.00.

GURNEE PARK DISTRICT POLICY MANUAL

C. Contractors

Any contractor who violates the provisions of this policy shall be subject to:

- 1) termination of contract at the option of the District,
- 2) debarment from participating in District contracts for a period not to exceed three years; and
- 3) any combination of these penalties and/or fine as described in this policy.

SECTION 3 FINANCE POLICIES

3.1 Purchasing Policy

Statement of Purpose

The purpose of establishing a purchasing policy is to maximize the purchasing power of public funds, to provide for the fair and equitable treatment of all persons involved in public purchasing and to provide safeguards for maintaining the quality and integrity of expenditures made by the district. The District is also subject to compliance with State statutes including the Prompt Payment Act (50ILCS, par 505/2) and Public Contracts (720 ILCS, Par 5/33 E-I). In the event there is a discrepancy between the District's policy and the governing State statute, the State statute will apply.

Administration of the Policy

3.1.1 Methods of Purchasing

All purchases in excess of \$1,000 for supplies, equipment and services shall be ordered using the requisition and purchase order approval process through the District's financial software. Purchase orders are not required for the following items/services:

- Utilities
- Bonds
- Tax warrants
- Evidences of indebtedness
- Magazines, books, periodicals
- Contractual services of those possessing professional skills (i.e. architects, lawyers, accountants and engineers)

3.1.2 Assignment of Authority

- A. *Purchases with an Anticipated Cost Greater than the Legal Threshold for Purchases which must be procured by Competitive Bidding*

The use of competitive sealed bids shall be used for purchases with an anticipated cost greater than the legal threshold for purchases which must be procured by competitive bidding in compliance with Article 8 of the Park District Code. Notice of bids shall be published in a local newspaper at least ten (10) days prior to the bid opening. A bid tabulation shall be submitted to the Board of Commissioners with a recommendation of award. Prior to final agreement for the purchase being made, all purchase arrangements and accepted bids must be approved by the Park Board of Commissioners.

The requirement for competitive bidding does not apply to contracts for:

- the services of individuals possessing a high degree of professional skill where the ability or fitness of the individual plays an important part, such as architects, engineers, accountants, lawyers, etc.;

GURNEE PARK DISTRICT POLICY MANUAL

- the printing of finance reports and department reports;
- the printing or engraving of bonds, tax warrants, or evidence of indebtedness;
- utility services such as water, electricity, gas and telephone;
- emergency acquisition of services or personal property provided such expenditures are approved by three-fourths of the members of the Board;
- the use, purchase, delivery, movement or installations of telecommunications and interconnect equipment, software or services;
- the use, purchase, delivery, movement or installation of duplicating machines and supplies;
- the procurement of goods or services from another government agency and the procurement of equipment previously owned by some entity other than the district itself;
- the purchase of items of an educational or instructional nature exclusive to a specific publisher or distributor;
- employment of personnel and the attendant payrolls;
- any other service or product otherwise exempt by statute.

B. *Purchases with a Dollar Value of Less than the Legal Threshold for Purchases which must be Procured by Competitive Bidding but \$2,500 or More.*

The Executive Director shall have the authority to enter into and make all expenditures, approve all change orders, and reject all bids on contracts for labor, services, work, property, material and supplies for the use of the District in which the expenditure does not exceed the legal threshold for purchases which must be procured by competitive bidding.

All items of an amount greater than or equal to \$2,500 for supplies, equipment and services shall be ordered on a purchase order approved through the Park District's financial software by an authorized agent of the Park District pursuant to the limits outlined as follows.

Approval limits for purchases with a dollar value of less than the legal threshold for purchases which must be procured by competitive bidding but \$2,500 or more are as follows:

- Department Heads have authority to approve purchases up to \$5,000
- The Executive Director, or, in the Executive Director's absence, by a Department Head upon delegation of this authority by the Executive Director, has authority to approve purchases up to the legal threshold for purchases which must be procured by competitive bidding.

Purchases with an estimated cost of \$2,500 or more, but less than the legal threshold for purchases which must be procured by competitive bidding shall be made by more than one written quotation and not less than three competitive

GURNEE PARK DISTRICT POLICY MANUAL

written quotations, whenever possible, except in those cases in which the Executive Director shall determine that only one written quotation can be obtained or that no benefit shall inure to the District by obtaining more than one written quotation. The business with the lowest responsible quote shall be awarded the sale.

C. *Purchases with a Dollar Value of less than \$2,500*

Purchase orders are not required for purchases less than \$2,500. All effort must be made to ensure that reasonable and adequate competition is upheld for all purchases of the Park District. All Park District purchases must have approval of at least a Supervisor level employee.

“Stringing” or segmenting a purchase to circumvent the bidding process or to reduce individual invoice totals to within the authority level of an employee is strictly prohibited and will result in disciplinary action.

3.1.3 Economy of Resources

The District understands the benefit of the economy of resources and purchasing through the participation in cooperative purchasing. Cooperative purchasing should be pursued whenever pricing and the desired product/service is most economical. Cooperative purchasing programs on the local, regional, State and National level should be identified when appropriate related purchasing is required. The District will seek to identify vendors of environmentally friendly products within the cooperative purchasing programs it participates in.

3.1.4 Full and Open Competition

Invitations for bids must contain the specifications, terms and conditions for the product or service. Public notice must be provided in a newspaper published in the District or in a general circulation newspaper not less than 10 days prior to the bid date. The public notice should include the place, date and time of the bid opening. Competitive bids must be sealed by the bidder and opened in the presence of two authorized full-time District employees, one of which being a management level employee, at a public bid opening at which the contents of the bids must be announced.

3.1.5 Ethics

The following principles and standards were developed using the principles of the National Association of Educational Buyers and the Institute for Supply Management Conflict of Interest. These principles and standards of ethical purchasing shall be followed:

- Consider the objectives and policies of the organization.
- Strive to obtain the maximum value for each dollar of expenditure.
- Avoid any personal business or professional activity that would create a conflict between personal interests and the interests of the District.

GURNEE PARK DISTRICT POLICY MANUAL

- Avoid soliciting or accepting money, loans, credits or preferential discounts and the acceptance of gifts, entertainment, favors or services from present or potential suppliers that might influence, or appear to influence, purchasing decisions.
- Grant all competitive suppliers equal consideration insofar as State or Federal statute and organizational policy permit.
- Conduct business with potential and current suppliers in an atmosphere of good faith, devoid of intentional misrepresentation.
- Demand honesty in sales representation whether offered through the use of a verbal or written statement, an advertisement, or a sample of the product.
- Receive the consent of the originator of any proprietary ideas and designs before using them for competitive purchasing purposes.
- Make every reasonable effort to negotiate an equitable and mutually agreeable settlement of any controversy with a supplier within the established policies of the District.
- Promote positive supplier relationships through courtesy and impartiality.
- Foster fair, ethical and legal trade practices.

District employees shall faithfully discharge their duties and shall refrain from knowingly engaging in any outside matters of financial interest incompatible with the impartial, objective, and effective performance of their duties. They shall not realize personal gain in any form which would influence improperly the conduct of their District duties. They shall not knowingly use District property, funds, position or power for personal or political gain. They shall inform their supervisors, Department Head and Executive Director, in writing, of reasonably foreseen potential conflicts. If the financial interest of an employee or Park Board Commissioner in a private firm or corporation is such that it could influence the decision-making process of the private firm or corporation, and the employee or Park Board Commissioner could also influence the decision-making process of the District in entering into or performing the contract:

- The District shall not enter into the contract, or shall cancel the contract, if the terms of the contract so permit; or
- The District employee or Park Board Commissioner shall take such action as is necessary to remove themselves from a relationship with the private firm or corporation that could influence the decision-making process of the private firm or corporation; or
- The District shall establish a procedure to remove any opportunity for the District employee or Park Board Commissioner to influence the entering into the contract by the District or the manner in which the contract is performed by the District.

Conduct by an employee that violates the District's policies, regulations or rules, pertaining to conflict of interest, shall constitute a breach of the employment contract and may lead to disciplinary actions.

3.1.6 Preferences

GURNEE PARK DISTRICT POLICY MANUAL

The Gurnee Park District gives preference to local business within the District's boundaries. These preferences do not preclude the purchase of goods and services from another company if the cost is less than the local business can offer.

3.1.7 Employee Reimbursements

The District recognizes that there are certain circumstances in which it may be necessary for District operations that employees make purchases on behalf of the District using personal funds and subsequently request reimbursement for those purchases. All reasonable efforts shall be made to plan for purchases in advance to avoid the need for employee reimbursements and employee reimbursements should only be used when all other reasonable avenues for making a purchase have failed and there is no alternative for making the purchase. Reimbursement for the purchase will be subject to approval of the purchase by the Supervisor, Manager, Department Head or Executive Director and submission of a detailed receipt. Requests for employee reimbursements shall be submitted no later than 30 days from the date of the purchase.

3.1.8 Park District Purchasing Cards (P-cards)

Purchases made with a Park District P-card are subject to all rules established in this policy.

Please refer to the "Using Park District P-cards – Operating Procedures" for more detailed information on the use of Park District P-cards.

3.1.9 Internet Purchases

Purchases made on the Internet for merchandise must be within the approved spending limits and follow other District purchasing policies and procedures. Purchases should be made only on secure sites.

3.1.10 Sales Tax

The Gurnee Park District is exempt from Illinois sales tax and all purchases should be made in accordance with the vendor's requirements to take advantage of this sales tax exemption. The District will not reimburse employees for the amount of sales tax paid, except for sales tax associated with the purchase of restaurant meals, as part of a purchase made on behalf of the District.

3.1.11 Discounts

Certain vendors may offer discounted pricing based on meeting specified dates for the payment for purchases. All reasonable efforts should be made to meet the processing requirements necessary to take advantage of the discounted prices.

3.1.12 Prompt Payment

All requests for payment should be submitted on a timely basis to avoid incurring finance or service charges.

GURNEE PARK DISTRICT POLICY MANUAL

3.1.13 Employee Purchases

Employees are not allowed to make purchases through the District for personal use or use the District's tax exempt status for personal purchases.

This policy shall be reviewed by the staff and the Board at least every two (2) years.

This policy shall be made available to the public at the Park District's office.

3.2 Disposal of Fixed Assets Policy

Statement of Purpose

The Board of Park Commissioners may, from time to time, decide to liquidate certain assets, which it has accumulated including land, buildings, equipment and other tangible items.

Administration of the Policy

Illinois Compiled Statutes carefully set forth the powers and procedures governing the sale or lease of real estate and shall be strictly adhered to in all instances.

The staff may recommend the sale or liquidation of certain pieces of equipment when it is determined that this is in the best interest of the District. Prior to disposal of any of the District's personal property, the Board shall adopt an ordinance declaring that property to be no longer necessary, useful to, or for the best interests of the park district, as required in Section 8-22 of the Park District Code. For the purpose of disposal of equipment, resale value shall be determined by an appropriately knowledgeable employee with the method of determination and/or value realized subject to approval of the appropriate department head. The appropriate form requesting approval to dispose must be completed and signed off on by the department head prior to disposal with the following guidelines being followed.

- A. Items with resale, scrap or salvage value of less than \$1,000 may be liquidated by the department Director. In disposing of such articles, the best interests of the District shall guide the procedure, which may include selling items of salvage value at any government-conducted public auction.
- B. When the resale value of the item to be liquidated is between \$1,000 and \$10,000, the Executive Director will first authorize the department Director to advertise the item in the local newspaper in order to solicit sealed bids. The Executive Director will then approve the final sale.
- C. When the resale value of the item to be liquidated exceeds \$10,000, the Board of Commissioners will first authorize the staff to solicit sealed proposals by advertising in the local newspaper and will then approve the final sale.

Proceeds, in the form of certified checks or cash (which must be accompanied by a receipt) from the salvage of any materials, equipment or supplies, are to be forwarded to the Finance Department. The funds will be deposited into the same fund that originally purchased the liquidated items or, if more appropriate, to the fund that had been responsible for the upkeep, maintenance and/or usage of the item.

If the items to be disposed of do not have any scrap or salvage value and are unusable by the District, upon completion of the appropriate form and approval of the department Director, they shall be disposed of in the following manner.

- A. If the item is broken, and not cost-effective to repair, it is thrown away.
- B. If the item is not broken, it is stored for future sale, sold or donated to a worthwhile community organization, as determined by the department Director. If it is

GURNEE PARK DISTRICT POLICY MANUAL

determined that a future sale or donation of the item is unlikely, and that it is not cost-effective to repair, the item is thrown away.

The liquidation, sale or disposal of any item, regardless of value, shall be reported to the Director of Business Services for inclusion in audit reporting procedures and updating of the Fixed Asset System.

3.3 Capital Replacement/Development Fund Policy

Statement of Purpose

To establish a long-range capital fund to systematically provide for current and future capital needs including major repairs, renovations and replacements of current assets and development of new assets. Further, to approve a special reserve fund to be designated as the Capital Replacement/Development Fund. The goal is to maintain 25% of operating expenditures as fund balances in each of the operating funds.

Administration of the Policy

3.3.1 Sources of Revenue for Capital Replacement/Development Fund

Fund Contributions: Individual operating funds such as corporate and recreation funds will annually contribute from each fund any amount in excess of the fund balance target amount. The amount of the transfer will be calculated annually based on the audited financial report at the end of each fiscal year.

3.3.2 Use of Funds

The funds in the Capital Replacement/Development fund will be used only to replace, repair and renovate existing assets as well as construct and acquire new assets necessary for the successful operations of the District.

3.3.3 Guidelines for Fund Use

The funds in Capital Replacement/Development fund can only be used to create or replace assets or group of assets costing more than \$10,000 and also have a useful life of at least one year.

3.3.4 Accounting Process and Records

The Park Board will receive annually during the budget process, for review and approval, the specific budget for the Capital Replacement/Development Fund. This budget will identify all anticipated sources of revenue, estimated fund balance and specific uses of funds for all current year expenditures.

In addition, separate records will be kept and be readily available of the transfer amount from each fund annually and the balance in the Capital Replacement/Development fund.

3.4 Land Cash Donation Policy

Statement of Purpose

The District, in cooperation with other local units of government and developers, may have a land and cash donation agreement based on a proportional qualitative relationship between negotiated donations and the impact of proposed developments.

Administration of the Policy

As the District is located within all or part of several different municipalities, the District acknowledges that uniformity of land and cash donation agreements may not exist in relation to what the District receives. The District recognizes that, through negotiations with municipalities and developers, the optimal proportional relationship between land and cash donations will be pursued.

3.4.1 Donation of Open Space Land or Payment of Fees in Lieu Thereof

Upon survey and review of the existing population and park lands available for neighborhood and community parks, it is the policy of the Gurnee Park District that developers wishing to develop residential real estate donate 10.0 acres per 1,000 ultimate population of said development or consider a cash donation in lieu of actual land donation or a combination of both. All donations shall be made to the Gurnee Park District and shall be used for neighborhood and/or community parks, recreation and open space purposes for the direct benefit of residents of the development/subdivision.

3.4.2 Guidelines for Policy:

Open Space Standards:

The Park District has adopted its Park and Recreation Master Plan and its respective Open Space Standards calling for 10 acres of open space land per 1,000 population within its jurisdiction. The distribution of open space land by Classification calls for the following:

Neighborhood Park	4.0 acres	/	1,000 population
Community Park	<u>6.0 acres</u>	/	1,000 population
Total Parks	10.0 acres	/	1,000 population

The Park District requires the donation of land or cash-in-lieu of land from annexation agreements and subdividers or developers be allocated, at the Board’s discretion, for neighborhood or community park purposes and that the cash-in-lieu of land may be appropriately allocated for the development of specific recreation facilities on park sites of benefit to residents of the subdivision.

POPULATION DENSITY

The population density of a development or subdivision required for calculating a donation will be based on the latest Illinois School Consulting Service table of estimated ultimate population per dwelling unit. The Gurnee Park District will utilize the most recent table available for making such calculations based upon the estimate of the number of bedrooms provided by the developer. Should the developer accurately establish a population density at less than that in the table, the developer’s calculations may be considered in making the appropriate calculations.

GURNEE PARK DISTRICT POLICY MANUAL

LAND DONATION

Based upon the donation policy, the land donated for each park site respectively, shall;

Contain a minimum of four (4) acres of buildable ground suitable in topography and soil types for permanent structures and active recreation use.

Be reasonably accessible and centrally located to all lots within the service area of the park.

Be adjacent to a public school site if a school is located within said subdivision.

Include wetlands and storm water control areas, only if such an area shall be acceptable to the District. The acres required for wetlands and detention or retention purposes will not be considered as fulfilling the land donation requirements.

Meet the Guidelines for the Function and Classification of The Park and Recreation Master Plan of the Gurnee Park District.

CASH DONATION IN-LIEU OF LAND:

It shall be the determination of the Park District of whether to accept the donation of land or cash-in-lieu of land or a combination of both from the developer.

Cash-in-lieu of land shall be based upon the “fair market value” of \$100,000 per acre of the land and such figures shall be used in making any calculations for the value of land that otherwise would have been dedicated as a park site.

DISTRIBUTION OF DONATIONS:

The size (acres) of a particular park facility, its location, and the number of such facilities required to meet public need shall be based upon the Park and Recreation Master Plan and the adopted standards, park classifications, population density, pedestrian barriers, park district boundaries and the natural features of the area. The final determination of these factors is to be made by the District.

GURNEE PARK DISTRICT POLICY MANUAL

FORMULA FOR PARK LAND DONATION POLICY:

Policy: Donation of 10.0 acres per 1,000 population of said development.

Formula:

Population
 No. of units _____ X Population per unit _____ = Population _____

Land Donation
 Population (thousands) _____ X 10.0 acres = Park Land Donated _____ acres

Cash Donation
 Park Land Donation _____ acres X Fair Market Value (\$100,000) = Cash Donation in
 Lieu of Land \$ _____

TABLE OF ESTIMATED ULTIMATE POPULATION PER DWELLING UNIT

Type of unit	Pre-School 0-4	Elementary Grades K-5 5-10 years	Junior High Grades 6-8 11-13 years	TOTAL Grades K-8 5-13 years	High School Grades 9-12 14-17 years	Adults 18+	Total Per Dwelling Unit
<u>Detached Single Family</u>							
2 bedroom	.113	.136	.048	0.184	.02	1.7	2.017
3 bedroom	.292	.369	.173	0.542	.184	1.881	2.899
4 bedroom	.418	.530	.298	0.828	.36	2.158	3.764
5 bedroom	.283	.345	.248	0.593	.3	2.594	3.77
<u>Apartments</u>							
Efficiency	0	0	0	0	0	1.294	1.294
1 bedroom	0	.002	.001	.003	.001	1.754	1.758
2 bedroom	.047	.086	.042	1.128	.046	1.693	1.914
3 bedroom	.052	.234	.123	0.357	.118	2.526	3.053

Source: Illinois School Consulting Service/Associated Municipal Consultants Inc. (1996) Naperville, IL

3.5 Investment Policy

Statement of Purpose

This investment policy (“Policy”) represents the formal effort of the Gurnee Park District (“District”) Board of Park Commissioners (“Park Board”) to develop, implement and monitor guidelines for the prudent investment and management of the District’s funds. Investments will be made with discretionary care and prudence under circumstances then prevailing, giving due regard to applicable law, the safety of capital as well as the probable income to be derived. The deposit and investment of all District funds not needed for immediate disbursement will be governed by this policy. In accordance with Illinois law all District funds not needed for immediate disbursement will be deposited within two (2) working days of collection at prevailing rates or better.

Administration of the Policy

The Treasurer is designated as the investment officer of the District. The Treasurer is responsible for investment decisions and activities, in consultation with the Executive Director and the Park Board. The Park Board is responsible for monitoring compliance with this Policy and revising and updating the Policy as appropriate. The Treasurer shall immediately report material changes in credit risk or market price to the Park Board so that appropriate action can be taken to control adverse developments. The Treasurer will also advise the Park Board if and when in the Treasurer’s judgment revisions in this policy are necessary or desirable.

The Treasurer shall make investments using the “prudent person” standard, which states that investments shall be made with judgment and care under circumstances then prevailing, which persons of prudence, discretion and intelligence exercise in the management of their own affairs, not for speculation, but for investment, considering the probable safety of their capital as well as the possible income to be derived.

The Treasurer, with the advice and assistance of the Executive Director, shall establish written procedures for the operation of the District’s investment program, consistent with this investment policy. Such procedures shall include specific delegation of authority to persons responsible for or assisting with investment transactions and reporting. The Treasurer shall establish a system of controls to regulate and monitor the activities of these persons.

The Treasurer shall be responsible for the obtainment, maintenance and periodic review for compliance with this policy, of all agreements (e.g. depository agreements, wire transfer agreements, safekeeping agreements, custody agreements) necessary or desirable to fulfill the investment responsibilities and requirements of this policy. The Treasurer will be assisted in this regard by the Executive Director and/or Executive District legal counsel, if and as necessary or appropriate.

The Treasurer shall not be held personally responsible for a specific security’s credit risk or market price changes, provided that the Treasurer has complied with applicable laws and this policy and has exercised diligence and good faith.

Neither the Treasurer, any other financial officer nor person acting in a similar capacity for the District or any park commissioner may:

- (1) have any interest, directly or indirectly, in any investments in which the District invests its funds; or

GURNEE PARK DISTRICT POLICY MANUAL

- (2) have any interest; directly or indirectly, in the sellers, sponsors or managers of those investments; or
- (3) receive in any manner, compensation of any kind from any investments in which the District invests its funds.

The foregoing restrictions shall not preclude a contract of deposit of monies, loans, or other financial services by the District with a local bank or local savings and loan association, regardless of whether the Treasurer, other financial officer or one or more park commissioners is/are interested in the bank or savings and loan association as a director, an officer, employee or holder of less than 7 ½% of the total ownership interest. The interested member or members of the Park Board must publicly state the nature and extent of their interest during deliberations concerning the proposed award of such a contract but shall not participate in any further deliberations concerning the proposed award. The interested member or members shall not vote on such a proposed award. Any member or members abstaining from participation in deliberating and voting under this provision may nevertheless be considered present for purposes of establishing a quorum. Award of such a contract will require approval by a majority vote of those park commissioners then holding office. Consideration and award of any such contract in which a park commissioner is interested may only be made at a regularly scheduled meeting of the Park Board.

3.5.1 Investment Objectives

The Park Board recognizes its responsibility as custodians of public funds. Investments shall be based on statutory constraints, prevailing market conditions and the District's authorized needs. Investment activities will be governed by the following specific objectives:

1. Safety of Principal – Every investment should be made with safety as the primary and overriding concern. Each investment transaction should ensure that loss of capital, whether from credit or market risk, is avoided. Investments shall be undertaken in a manner that seeks to ensure the preservation of capital in the overall portfolio. Diversification is required, as appropriate, so that potential losses on individual securities and/or financial institutions do not exceed the income generated from the remainder of the portfolio.
2. Liquidity – Maturity and marketability aspects of investments should tie in directly with the anticipated cash flow needs of the District.
3. Rate of Return – The highest rate of return on investments should be sought consistent with the safety of principal, the cash flow characteristics of the portfolio and legal restrictions for return on investment.

GURNEE PARK DISTRICT POLICY MANUAL

4. Public Trust – The District’s commissioners and officers should avoid any investment transaction or practice which in appearance or fact might impair public confidence in its stewardship of District funds. This policy is designed to prevent losses of funds due to fraud, employee errors, misrepresentation by third parties, or imprudent action by park district employees.

3.5.2 Responsibility for Policy Implementation and Adherence

The Treasurer is designated as the investment officer of the District. The Treasurer is responsible for investment decisions and activities, in consultation with the Executive Director and the Park Board. The Park Board is responsible for monitoring compliance with this Policy and revising and updating the Policy as appropriate. The Treasurer shall immediately report material changes in credit risk or market price to the Park Board so that appropriate action can be taken to control adverse developments. The Treasurer will also advise the Park Board if and when in the Treasurer’s judgment that revisions in this policy are necessary or desirable.

The Treasurer shall make investments using the “prudent person” standard, which states that investments shall be made with judgment and care under circumstances then prevailing, which persons of prudence, discretion and intelligence exercise in the management of their own affairs, not for speculation, but for investment, considering the probable safety of their capital as well as the possible income to be derived.

The Treasurer, with the advice and assistance of the Executive Director, shall establish written procedures for the operation of the District’s investment program, consistent with this investment policy. Such procedures shall include specific delegation of authority to persons responsible for or assisting with investment transactions and reporting. The Treasurer shall establish a system of controls to regulate and monitor the activities of these persons.

The Treasurer shall be responsible for the obtainment, maintenance and periodic review for compliance with this policy, of all agreements (e.g. depository agreements, wire transfer agreements, safekeeping agreements, custody agreements) necessary or desirable to fulfill the investment responsibilities and requirements of this policy. The Treasurer will be assisted in this regard by the Executive Director and/or District legal counsel, if and as necessary or appropriate.

The Treasurer shall not be held personally responsible for a specific security’s credit risk or market price changes, provided that the Treasurer has complied with applicable laws and this policy and has exercised diligence and good faith.

Neither the Treasurer, any other financial officer nor person acting in a similar capacity for the District or any Park Commissioner may:

- have any interest, directly or indirectly, in any investments in which the District invests its funds; or
- have any interest; directly or indirectly, in the sellers, sponsors or managers of those investments; or

GURNEE PARK DISTRICT POLICY MANUAL

- receive in any manner, compensation of any kind from any investments in which the District invests its funds.

The foregoing restrictions shall not preclude a contract of deposit of monies, loans, or other financial services by the District with a local bank or local savings and loan association, regardless of whether the Treasurer, other financial officer or one or more Park Commissioners is/are interested in the bank or savings and loan association as a director, an officer, employee or holder of less than 7 ½% of the total ownership interest. The interested member or members of the Park Board must publicly state the nature and extent of their interest during deliberations concerning the proposed award of such a contract, but shall not participate in any further deliberations concerning the proposed award. The interested member or members shall not vote on such a proposed award. Any member or members abstaining from participation in deliberating and voting under this provision may nevertheless be considered present for purposes of establishing a quorum. Award of such a contract will require approval by a majority vote of those Park Commissioners then holding office. Consideration and award of any such contract in which a Park Commissioner is interested may only be made at a regularly scheduled meeting of the Park Board.

3.5.3 Designation of Depository/Change in Designated Depository/Notification of Sureties

Designations of depositories shall be made by the Park Board, with the advice of and in consultation with the Treasurer. The Treasurer and each park commissioner will be required to indicate any personal financial interest in any depository proposed for designation. Before receiving any deposit of District funds, the financial institution to be designated must provide the District with copies of the last two (2) sworn statements of resources and liabilities or condition filed with the financial institution's state or federal regulator. While acting as a District depository, a financial institution must continue to furnish the District with such statements within 45 days of the end of each quarter.

Any financial institution selected by the District as a depository shall provide normal banking services, including but not limited to, checking accounts, wire transfers, purchase and sale of U.S. Treasury securities and safekeeping services. The District will not maintain funds in any financial institution that is not a member of the Federal Deposit Insurance Corporation ("FDIC"), Banking Insurance Fund ("BIF") or Savings Association Insurance Fund ("SAIF") system. In addition, the District will not maintain funds in any institution not willing or capable of posting required collateral for deposited funds in excess of FDIC, BIF, or SAIF insurable limits.

Fees for banking services will be mutually agreed to by an authorized representative of the depository and the Treasurer on an annual basis. Fees for services shall be substantiated by a monthly account analysis and shall be reimbursed by means of compensating balances.

Funds may not be transferred to a new depository until at least ten (10) days after the new depository is designated and the new depository has provided the District with the statements of resources and liabilities or condition as described above.

The Treasurer will notify its sureties of the change in designated depositories at least five (5) days before the actual transfer of funds.

GURNEE PARK DISTRICT POLICY MANUAL

3.5.4 Authorized Investments

District investments shall be limited to the following investments so long as they are authorized by applicable State law, and such additional investments as shall hereinafter be authorized by the Park Board consistent with State law:

1. United States Government guaranteed obligations such as bonds, notes, certificates of indebtedness, treasury bills or other securities which are guaranteed by the full faith and credit of the United States of America as to principal and interest.
2. United States Government direct obligations such as bonds, notes, debentures, or similar obligations of the United States of America or its agencies. For purposes of this provision, "agencies of the United States of America" includes: (a) the federal land banks, federal intermediate credit banks, banks for cooperative, federal farm credit banks, or any other entity authorized to issue debt obligations under the Farm Credit Act of 1971 as amended; (b) the federal home loan banks and the federal home loan mortgage corporation; and (c) any other agency created by Act of Congress.
3. Interest bearing savings accounts, interest bearing certificates of deposit, or interest bearing time deposit accounts, or any other investments constituting direct obligations legally issued by banks, as defined by the Illinois Banking Act. Such investments may be made only in banks which are insured by the BIF (FDIC).
4. Savings and loan securities (such as shares or investment certificates) legally issued by savings banks or savings and loan associations incorporated under the laws of any state or the United States, provided that the shares or investment certificates are insured by SAIF (FDIC).
5. Interest bearing bonds of the District or any county, township, city, village, incorporated town, municipal corporation or school district. The bonds must be registered in the name of the District or held under a custodial agreement at a bank.
6. Federal National Mortgage Associations (Fannie Mae) short-term discount obligations.
7. Money market mutual funds (i.e. mutual funds which invest in securities maturing within 90 days of purchase) registered under the Investment Company Act of 1940 provided that the portfolio of any such money market mutual fund consists solely of United States Government-backed securities.

GURNEE PARK DISTRICT POLICY MANUAL

8. Dividend-bearing share accounts, share certificate accounts or class of share accounts of any credit union chartered under federal or Illinois law, provided that its principal office is located in Illinois. All such accounts must be insured by applicable law.
9. Funds managed, operated and administered by a bank, subsidiary of a bank, or subsidiary of a bank holding company or use the services of such an entity to hold and invest or advise regarding the investment of District funds.
10. Repurchase agreements of government securities as defined in the Government Securities Act of 1986 subject to the provisions of said Act and the regulations issued thereunder. The government securities, unless registered or inscribed in the name of the District, shall be purchased through banks or trust companies authorized to do business in Illinois.
11. Illinois Park District Liquid Asset Fund Plus.
12. The Illinois Funds.
13. Short-term obligations, i.e. commercial paper, maturing within 180 days of date of purchase of corporations organized in the United States with assets exceeding Five Hundred Million Dollars (\$500,000,000) provided that: (i) such obligations are rated at the time of purchase at one of the three highest classifications established by at least two (2) standard rating services; and (ii) no more than 33% of the District's funds may be invested in such obligations at any time; and (iii) such purchases do not exceed 10% of the corporation's outstanding obligations.

Deposits not collateralized or insured by an agency of the federal government or other approved share insurer shall not exceed:

- a. 75% of the capital stock and surplus of the bank.
- b. 75% of the net worth of the savings bank or savings and loan association.
- c. 50% of the unimpaired capital and surplus of the credit union.

3.5.5 Selection of Investment Instrument

The selections shall be based on the following procedures:

1. Determine the needs of the District by evaluating the current portfolio and cash on hand and anticipated future receipts and expenses for the adequacy of meeting future cash needs.

GURNEE PARK DISTRICT POLICY MANUAL

2. Develop a schedule to satisfy those needs with specific future dates.
3. Review the various alternatives available to determine the investment with the highest yield that is consistent with applicable law and the needs, schedule of maturity and investment policy of the District considering the institution, amount, maturity date, yield and security.
4. Select investment alternative meeting all requirements of this policy and applicable law, based on the following:
 - a. If certificates of deposit or time deposits are to be used, the District will solicit telephone quotes from at least four (4) institutions, qualified for designation in accordance with this policy and State law.

-OR-

- b. Place such investments through a financial institution whenever comparable opportunities arrive, especially when the investment is protected by the institution through the provision of collateral as approved by the District.
- c. The Illinois Funds or the Illinois Park District Liquid Asset Fund Plus (IPDLAF+) may be used.

The selection of investments is dependent upon applicable law and the type of investments authorized by the Park Board. If a new type of investment not presently authorized by the Park Board is requested by the Treasurer, it will be necessary for the Treasurer to discuss the investment with the Park Board before any action is taken. The change in the investment policy will then be brought to the Park Board for approval.

3.5.6 Safekeeping and Collateral

The Treasurer shall negotiate the security for all investments with the institution in which the District's funds are deposited or from which the investment is being purchased. The Treasurer shall determine the type and amount of collateral required in accordance with these policies and Illinois law.

The Treasurer will review on a monthly basis the ratio of the fair market value of collateral to the amount of the funds secured and shall request additional collateral when the ratio declines below the minimum required level.

The Treasurer may also require an institution to provide collateral which exceeds the minimum collateral requirements of this policy when, in the Treasurer's judgment, such additional collateral is desirable given his review of the financial condition or changes therein of the institution in/with which deposit or investment will be or has been made.

GURNEE PARK DISTRICT POLICY MANUAL

Third party safekeeping is required for all collateral. To accomplish this, depending on the type of collateral, the collateral can be held at:

1. A Federal Reserve Bank or its branch office; or
2. at another custodial facility – generally in a trust department through book-entry at the Federal Reserve, unless physical securities are involved; or
3. by an escrow agent of the pledging institution; or
4. a financial institution on the Illinois State Treasurer’s approved list of safekeeping banks.

Safekeeping must be documented by an approved written agreement in the form of a safekeeping agreement trust agreement, escrow agreement or custody agreement. Each designated agent shall issue a safekeeping receipt to the District listing the specific instrument, rate, maturity date and other pertinent information.

All securities pledged as collateral must mature after the maturity date of the investments which they secure. The market value of the pledged securities must be at least 110% of the market value of the amount of funds which exceed the insured limits of the BIF or SAIF of the FDIC on the day of deposit/investment. Acceptable forms of collateral include the following:

1. U.S. Government Securities
2. Obligations of Federal Agencies or Instrumentalities
3. Obligations of the State of Illinois
4. General obligation bonds of county or municipal corporations of Illinois or any other political subdivision of Illinois which are rated “A” or better by Moody’s or Standard and Poor’s rating services.

3.5.7 Application of Investment Income

The Treasurer may combine moneys from more than one fund of the District for the purpose of investing such moneys. When funds are combined for investment purposes, the moneys combined for such purposes shall be accounted for separately in all respects and the earnings from such investment shall be separately and individually computed and recorded and credited to the fund for which the investment was acquired.

3.5.8 Reporting Requirements

The Treasurer shall provide a written report to the Park Board monthly at its regular meeting detailing outstanding investments by type, issuer, interest rate, maturity and cost by fund, earnings for the current period and year to date, and type, amount and location of collateral. The report will also address overall portfolio performance, any compliance

GURNEE PARK DISTRICT POLICY MANUAL

problems or deviations from this Investment Policy, and any material variations from cash flow projections affecting portfolio performance and the reasons therefor.

The Treasurer shall also provide a written annual report on the District's investment program and activity within thirty (30) days following the close of the District's fiscal year. The report will include a review of the year's overall investment performances as well as a projection of what may be anticipated in the future. The Treasurer will provide all such information and related assistance to the Director for purposes of preparation of the District's annual budget and appropriation ordinance and any working budget of the District.

This policy shall be reviewed by the staff and the Board at least every two (2) years to ensure its consistency with respect to the objectives of safety, liquidity, yield and its relevance to current laws and financial trends.

This policy shall be made available to the public at the Park District's office.

3.6 Capital Asset Policy

Statement of Purpose

Assets that have a value of \$10,000 or more and have a useful life of five years or more should be capitalized in the year they are acquired. Improvements done to existing assets that increase the value of the assets should also be capitalized. Normal repairs that merely maintain the asset in its present condition should be recorded as expenditure and should not be capitalized. These assets are categorized as various classes such as Land, Buildings, Improvements other than buildings, Machinery and Equipment, Vehicles, and Computer Equipment.

Administration of the Policy

3.6.1 Valuation

All assets reported as capital assets should be recorded at their historical cost. Cost, for this purpose, includes not only the purchase price or cost of construction, but also any other charges incurred “to place the asset in its intended location and condition for use.”

3.6.2 Capital Asset Classes

Capital assets are classified into four major groups including land, buildings, improvements other than buildings, and machinery and equipment.

The “land” account includes all land purchased or otherwise acquired by the District. The land account should include not only the cost of land itself, but also the cost of preparing land for its intended use. Intent, for this purpose, should be judged as of the date of acquisition.

The “buildings” account includes the value of all buildings at purchase price or construction cost. The cost should include all charges applicable to the building, including brokers or architect’s fees and interest on borrowed money during construction.

The “improvements other than buildings” account is used for permanent (i.e., non-detachable) improvements that add value to land (e.g., fences, retaining walls). This account also is used for leasehold improvements (i.e., permanent improvements the Park District makes to property it is leasing under an agreement classified as an operating lease).

The “machinery and equipment”, “vehicles”, and “office furniture and equipment” accounts consist of property that does not lose its identity when removed from its location and is not changed materially or expended in use. This property should be recorded at cost, including freight, installation and other charges incurred to place the asset in use.

Donated assets should be recorded at their estimated fair market value at the date of donation. This rule applies only to donations made from outside the financial reporting entity.

GURNEE PARK DISTRICT POLICY MANUAL

3.6.3 Useful Life

Following is a listing of the different classes of assets and their standard useful lives.

Class	Years
Land	No limit
Buildings	30
Improvements other than buildings	20
Machinery and Equipment	10
Vehicles	5
Office Furniture and Equipment	7

3.6.4 Procedure for Additions & Disposals of Assets

The Finance Department is responsible for keeping the capital asset records up to date. But the primary responsibility for providing the correct information to the Finance department and periodically verifying the accuracy of the information belongs to the Department Heads.

A. Additions

Additions to capital asset account group will be done on an annual basis by the Director of Business Services. All assets recorded during the current fiscal year are defined as current year additions. These should include purchases of new as well as used assets, all donated assets and assets acquired through capitalized leases. Once the capital asset list is updated reflecting current year additions, it will be given to Department Heads to verify and make corrections.

B. Disposals

All items sold, traded-in, scrapped, abandoned or in any way removed from service during the current fiscal reporting period are classified as disposals. Disposals must be authorized by the Board in accordance with Policy 3.2 of this Manual. When the Department Head receives an updated list of the capital assets at the end of each fiscal year, the Department Head should verify the information and see if all assets are still in service. If there are assets on the list that are no longer in service, they should be retired.

3.6.5 Depreciation

Depreciation is used to reflect the economic loss in the value of an asset. Generally Accepted Accounting Principles (GAAP) requires that the method used to allocate the cost of a capital asset over its estimated useful life be as equitable as possible to the periods during which services are obtained from the use of the asset.

In most cases, the straight line method of depreciation will be used for all assets.

3.7 Bill Payment Policy

Statement of Purpose

It is the policy of the Gurnee Park District Board of Commissioners and staff to pay all of its bills in a timely manner according to the State of Illinois State Statutes.

Administration of the Policy

District staff will use all payment plans that would enable them to receive discounts or bonuses for prepayment of bills according to specific vendor guidelines, resulting in a savings for the Agency. The appropriate department head will review and send all bills to the Executive Director for final approval. Bills will be processed monthly and paid within thirty (30) days of receipt unless held for nonperformance of services, contract, or any dispute over legitimacy of charges being billed. If a bill is not paid within thirty (30) days of receipt, the Park Board shall be informed, and written notice of the reason for non-payment will be sent to the vendor in accordance with the Illinois Local Government Prompt Payment Act (50 ILCS 505/1 et seq.)

3.8 Fund Balance Policy

Statement of Purpose

The purpose of this policy is to establish the principles and parameters to which a Fund Balance target will be defined at the beginning of each budget period. This policy is established to provide financial stability, cash flow for operations, and the assurance that the District will be able to respond to emergencies with fiscal strength.

In the event that unexpected situations may cause the District to fall below the minimum level, certain steps will be followed to correct the deficiency, as outlined in the section below “Minimum Target Balances”.

Administration of the Policy

3.8.1 Definitions

Governmental Funds – are used to account for all the District’s general activities, including the collection and disbursement of earmarked monies (special revenue funds), the acquisition or construction of general capital assets (capital replacement/development fund), and the servicing of long-term debt (debt service funds). The General Fund is used to account for all activities of the District not accounted for in some other Fund.

Fund Balance – the difference between assets and liabilities in a Governmental Fund

Operating Expenditures – total expenditures minus capital and debt service.

Governmental Funds – Fund Balance will be composed of three primary categories:

1. Non-spendable Fund Balance – the portion of a Governmental Fund’s fund balance that are not available to be spent, whether short or long-term, in either form or through legal restrictions (inventories, prepaid items, land held for resale and endowments).
2. Restricted Fund Balance – the portion of a Governmental Fund’s fund balance that is subject to external enforceable legal restricts (grants, debt proceeds, tax levies).
3. Unrestricted Fund Balance – (three categories)
 - a. Committed Fund Balance – the portion of a Governmental Fund’s fund balance constrained to specific purposes by the government itself, using its highest level of decision-making authority; to be reported as committed, amounts cannot be used for any other purpose unless the government takes the same highest-level action to remove or change the constraint.
 - b. Assigned fund balance - portion of a Governmental Fund’s fund balance the government intends to use for a specific purpose; intent can be expressed by the governing body or by an official or body to which the governing body delegates the authority.

GURNEE PARK DISTRICT POLICY MANUAL

- c. Unassigned Fund Balance – available expendable resources that are not the object of a tentative management plan.

All Gurnee Park District funds are Governmental Funds.

3.8.2 Guiding Parameters

It is the District's philosophy to support long-term financial strategies, where fiscal sustainability is its first priority, while also building funds for future growth. It is essential to maintain adequate levels of fund balance to mitigate current and future risks and to ensure stable tax rates. Credit rating agencies carefully monitor levels of fund balance to evaluate the District's credit worthiness.

The following parameters will be used as part of the budget process to establish targets for the following funds:

General Fund – the unrestricted fund balance target should represent three months of operating expenditures for the budget year being prepared. Balances above the three month target may be transferred to the Capital Replacement/Development Fund with Board approval.

Recreation Fund – the unrestricted fund balance target should represent three months of operating expenditures for the budget year being prepared. Balances above the three month target may be transferred to the Capital Replacement/Development Fund with Board approval.

Capital Replacement/Development Fund – no target is established for this fund. Capital projects are funded through transfers from the General Fund and Recreation Fund as approved by the Board along with interest earned on fund balance. This fund is used to replace aging capital items as well as for the development of new capital or infrastructure. Amounts set aside for capital will be considered restricted, committed or assigned depending on the intended source/use of the funds as approved by the Board.

Social Security, IMRF, Liability Insurance and Audit Funds – these funds have a targeted fund balance of three months of operating expenditures for the budget year being prepared. These funds will be monitored, and the taxes levied to support them will be adjusted to ensure they operate within the target range. It may take more than one levy cycle to ensure the funds are operating within the proper range.

Paving and Lighting Fund - the unrestricted fund balance target should represent three months of operating expenditures for the budget year being prepared. Balances above the three month target may be used for capital expenditures related to paving and lighting made out of this fund.

Special Recreation Fund – no target is established for this fund. This fund is used to account for revenues derived from a specific annual property tax levy which is disbursed to the Warren Special Recreation Association to provide special recreation programs for the handicapped and impaired. This fund is also used to make ADA improvements to the District's park infrastructure.

GURNEE PARK DISTRICT POLICY MANUAL

Site & Construction Fund – no target is established for this fund. This fund is used to account for capital expenditures associated with acquiring, improving, and maintaining the District's properties and equipment. Financing is provided from the proceeds of sale of general obligation bonds, developer donations, grants and interest earned on investments.

Bond & Interest Fund – No target is established for this fund. This fund is used to accumulate monies for the District's retirement of general obligation bonded debt. Financing is provided by an annual tax on property levied for the purpose of retiring bonded indebtedness.

3.8.3 Flow Assumptions

Some projects (funds) are funded by a variety of resources, including both restricted and unrestricted (committed, assigned and unassigned). When restricted funds exist, those funds are used first, then unrestricted. For unrestricted funds, committed funds are used first, then assigned, then unassigned.

3.8.4 Authority/Reporting

Staff will prepare and include in the budget document a schedule that shows the status of the District's balances compared to the Targets outlined in this policy. The Executive Director of the Gurnee Park District is given authority within this policy to assign fund balance to specific projects/expenditures.

3.8.5 Minimum Targets

Management will monitor the major revenue collections and the amount of cash available by reviewing the monthly financial reports. During the year, if revenue projections suggest that revenue will not meet expectations and the fund target(s) will not be met by year-end, the Executive Director will take the following actions to reach the goals established in the adopted budget:

- Review expenses with Department Heads,
- Reduce capital asset expenditures,
- Reduce operational expenditures, where appropriate, while maintaining the adopted budget goals,
- Present to the Board of Park Commissioners other expenditure control options, including those that might modify the goals established in the adopted budget.

3.8.6 Deviations from the Policy

Any deviations from this Policy must be approved by a majority of the Board of Park Commissioners with a plan for adhering to this Policy within a defined period of time.

3.9 Internal Control Policy

Statement of Purpose

The Gurnee Park District will maintain a system and environment of internal control to safeguard its assets against loss, check the accuracy and reliability of its accounting data, promote operational efficiency, and encourage adherence to prescribed financial policies adopted by the Park District Board of Commissioners.

Administration of the Policy

3.9.1 Control Environment

The Park District Board of Commissioners and Management Staff will demonstrate and promote a commitment to integrity and ethical values. Management Staff, through oversight of the Board of Commissioners, will establish structures, reporting lines and appropriate authorities in pursuit of objectives. The District will demonstrate a commitment to attract, develop and retain competent individuals in alignment with the mission and vision of the District. Individuals will be held accountable for their internal control responsibilities as it relates to their job duties.

3.9.2 Objective of Internal Control

A system of internal controls should be able to provide reasonable assurance that these objectives have been met:

- A. Authorization - All transactions are properly authorized by management per applicable financial policies.
- B. Recording transactions – Transactions are recorded as necessary (1) to permit preparation of financial statements in conformance to statutory requirements and accounting principles generally accepted in the United States, and (2) to maintain accountability for the District assets.
- C. Access to assets – Access to assets and records should be permitted only with management’s authorization.
- D. Periodic independent verification – The records should be checked against the assets by someone other than the persons responsible for the records or the assets. Examples of independent verification are monthly bank reconciliations and periodic counts of inventory.
- E. Segregation of duties – The organizational plan should separate functional responsibilities. In general, when the work of one employee is checked by another, and when the responsibility for custody of assets is separate from the responsibility for maintaining the records relating to those assets, then there is appropriate segregation of duties.

3.9.3 Financial Policies

The Park District Board of Commissioners has adopted the following financial policies:

- Acceptance of Gifts
- Annual Operating Budget
- Bill Payment

GURNEE PARK DISTRICT POLICY MANUAL

- Capital Assets
- Comprehensive Revenue
- Debt Issuance and Management
- Disposal of Fixed Assets
- Fund Balance
- Investment
- Land Cash Donation
- Purchasing

Each financial policy listed above contains specific internal control details. **It is the responsibility of the Business Services Department to ensure that the financial policies listed above are adhered to by District personnel.** The Director of Business Services will be responsible to ensure that all financial policies are reviewed in a timely manner.

3.9.4 Written Procedures

Written procedures will be maintained by the Business Services Department for all financial functions, processes and transactions of the District (i.e. cash handling, payroll, accounts payable, customer registrations, customer refunds, employee purchasing cards, online banking activities and journal entries). These procedures shall embrace sound internal control principles.

3.9.5 Business Services Department Internal Control Responsibilities

The Business Services Department shall issue internal control procedures based upon deficiencies that have been identified by the Park District Board of Commissioners, District Staff or the independent auditors. The Business Services Department shall ensure that a good faith effort is made to implement all independent auditor recommendations pertaining to internal control. The Business Services Department will administer an “in-house audit” program to regularly and systematically review and monitor internal control procedures and compliance with federal and state regulatory requirements pertaining to internal controls or financial reporting.

The Business Services Department will reconcile all District bank and investment accounts on a monthly basis. The reconciliations will be performed by an individual who is not responsible for regular revenue deposits or accounts payable functions. The Director of Business Services will review all bank and investment account reconciliations.

3.9.6 Department Head Responsibilities

Each department head is responsible to ensure that internal control procedures, including those issued by the Business Services Department, are followed throughout their department.

3.9.7 Financial Reporting

The District will prepare its financial reports in conformance with applicable statutes and, where applicable, accounting principles generally accepted in the United States. The Governmental Accounting Standards Board (GASB) is responsible for establishing

GURNEE PARK DISTRICT POLICY MANUAL

generally accepted accounting principles for state and local governments through its pronouncements (Statements and Interpretations).

An Annual Comprehensive Financial Report (ACFR) will be prepared annually. The ACFR will be presented to the Board of Commissioners at the first Board meeting following the completion of the report, when possible, but no later than the October Board meeting following the end of the fiscal year. The ACFR will be made available for review by the public immediately following the presentation at the Board meeting.

The Board of Commissioners will be presented with monthly financial reports for the month ended prior to the date of the meeting. The financial reports should include no less than:

- Monthly Budget Report - revenue and expenditures summary by fund
- Balance Sheet Report - assets, liabilities and equity (fund balance) for each fund
- Treasurer's Report – month end fund balance of each fund tied to the month end balance for all bank accounts and investments held by the Park District

The reports listed above along with any other financial reporting for the District are to be created either directly from the District's financial software or the information extracted directly from the District's financial software if the final report is prepared using a software other than the District's financial software (i.e. Microsoft Excel).

Each month, the Business Services Department will also distribute account by account detailed monthly budget reports created directly from the District's financial software to District management.

The Executive Director and Director of Business Services are responsible for the accuracy, documentation and submission of all financial reports. Material changes in the District's financial condition will be reported to the Board of Commissioners in an urgent manner.

3.9.8 Audit

The District shall have an annual financial audit conducted by an independent public accounting firm. This audit shall be conducted in accordance with generally accepted accounting principles (GAAP). The Governmental Accounting Standards Board (GASB) is responsible for establishing GAAP for state and local governments through its pronouncements (Statements and Interpretations).

The independent audit firm shall include a report in the annual financial audit on the internal control practices of the District including any deficiencies. The Executive Director and Director of Business Services are responsible for addressing any and all deficiencies included in the audit report.

3.10 Budget Policy

Statement of Purpose

The Board of Park Commissioners will adopt an annual budget in order to provide the best possible facilities, programs, and services to the public and to establish and enforce controls for the expenditure of funds within the limitations of the budget. The operating budget is the District's annual financial plan.

Administration of the Policy

The fiscal year of the District shall commence on the first day of May and end on the thirtieth day of April, and this period shall constitute the budget year of the District.

3.10.1 Operating Budget

The major guides used to prepare the annual operating budget will be the current Comprehensive Strategic Plan (includes Community Needs Assessment) and the Park District Master Plan.

Revenues will be budgeted conservatively, but realistically, considering; past experience, the volatility of the revenue source, inflation and other economic conditions, and the cost of providing services.

Expenditures will also be budgeted conservatively considering: a likely scenario of events, specific identified needs of services, historical trends, and inflation and other economic trends.

The District will adhere to the policy of a balanced operating budget. Under normal conditions, operating expenditures are less than the non-debt related real estate taxes and fees for services. Surplus from operations funds a portion, if not all, of ongoing capital improvement needs. A total budget deficit will only be the result of discretionary spending approved by the Board for capital improvements. *One-time or special purpose revenues* will be used to finance capital projects or for expenditures required by the revenue, and not to subsidize recurring personnel costs or other operating costs.

The annual operating budget will be prepared on the cash basis. The budget will be structured on a fund basis. The budget will be sufficiently detailed to identify all significant sources and uses of funds. The format will include the following on a fund-by-fund basis: estimated beginning fund balances, estimated revenue, projected expenditures, and the estimated year end fund balances. Actual prior year data and projected current year results will be presented for comparative purposes.

The annual operating budget will also contain narrative highlights and explanations by fund for the revenues and expenditures presented in the budget.

3.10.2 Budget and Appropriation Ordinance

No later than the end of the first quarter of each fiscal year, the Board will pass a combined budget and appropriation ordinance appropriating moneys which the Board determines are necessary to defray all necessary expenses and liabilities of the District. It is the

GURNEE PARK DISTRICT POLICY MANUAL

recommended practice of the District to appropriate expenditures 20% higher than the annual operating budget to account for additional revenue received during the fiscal year.

No later than thirty (30) days prior to final passage of the budget and appropriation ordinance, the President shall prepare and submit a proposed ordinance to the Board. The ordinance shall itemize the materials or services for which District moneys will be spent. Each item shall be for a single purpose.

The Secretary of the District shall arrange to make the ordinance conveniently available for public inspection. The Secretary shall publish notice of at least one public hearing in a newspaper having a general circulation in the District. Such notice must be published at least seven (7) days prior to the public hearing in which the ordinance is approved.

Upon conclusion of the public hearing on the proposed budget and appropriation ordinance, the Board shall make such revisions and amendments as it deems necessary and shall adopt the ordinance.

Within thirty days after the adoption of the annual budget and appropriation ordinance, the Secretary shall file a certified copy of the ordinance with the County Clerk. The Secretary shall file with the ordinance an estimate, certified by the Treasurer, of the revenues the District anticipates receiving during the fiscal year covered by the ordinance.

After the adoption of such budget and appropriation ordinance, no further or other appropriation shall be made prior to the adoption or passage for the next succeeding annual appropriation ordinance. The Board may authorize the making of transfers between items in any fund in the ordinance, not exceeding, in the aggregate, ten percent (10%) of the total amount appropriated in such fund by the ordinance. The Board may amend the ordinance from time to time by the same procedure as is provided for in the original adoption of the budget and appropriation ordinance. After the first six months of any fiscal year, the Board may, by a two-thirds vote, transfer from any appropriation item anticipated unexpended funds to any other item of appropriation.

3.10.3 Expenditures Not Contained in Budget

The Board, or any officer, employee or agent of the Board shall not during any fiscal year make any expenditures or enter into any contract or agreement, or employ any person, where such contract, agreement or employment calls for the expenditure of moneys belonging to the District to create any liability on the part of the District, unless such expenditure is contained in the budget and appropriation ordinance as finally approved and is authorized for such fiscal year.

In case of emergencies such as fires, floods, storms, unforeseen damages, or other catastrophes happening after the adoption of the annual appropriation ordinance, the Board may, by a $\frac{3}{4}$ vote authorize expenditures necessary to meet such emergencies. If the purchase must be made prior to a Board meeting, then this vote may be taken by the Executive Direct by phone or electronically and then ratified at the next regular Board meeting.

3.11 Debt Issuance and Management Policy

Statement of Purpose

The purpose of this policy is to set standards for the issuance and subsequent management of debt. This Debt Issuance and Management Policy will act as a guide to finance the growth and development of the District when issuance of debt is needed. Any short-term, long-term or annual rollover debt placed on the District must be understood and approved by the Board of Commissioners.

Administration of the Policy

3.11.1 Responsibilities of the Board of Commissioners and Staff

The Board of Park Commissioners, the Executive Director, and staff will act prudently and in the best interest of the District and the community they represent. The District will adhere to all relevant debt/bond legal statutes. Debt will only be taken on if it is effective and efficient in meeting and furthering the District's strategic plan, the park and open space master plan, capital improvement plan and the mission, vision, and values.

Prior to any future issuance of debt, the District must take into consideration the following guidelines outlined within this policy. In addition to the guidelines within this policy, other factors like current economic conditions, the District's current debt repayment schedule, and other risk factors that could be assumed with acquiring more debt, must be reviewed during the process.

3.11.2 Compliance Officer

The compliance officer of all issuance of debt and bond sales is the Director of Business Services. The Executive Director will act/serve in his absence or vacancy of the position. The compliance officer will be assigned the responsibilities which include, but are not limited to the following:

- Responsible for monitoring and filing all necessary documentation
- Training for responsible commissioners or employees with regard to tax and disclosure requirements
- Internal reporting of compliance efforts
- Preservation of institutional knowledge

3.11.3 Debt and Bond Administrative Review

Annual review of all bond series or debt must be done to maintain compliance with all terms and conditions. A "*Post Issuance Compliance Checklist*" is prepared by legal counsel for all debt issuances which details the compliance requirements. The Director of Business Services is responsible for the annual review and will report their review of the policy to the Board of Commissioners at a regularly scheduled public Board meeting.

GURNEE PARK DISTRICT POLICY MANUAL

3.11.4 Record Retention

Record retention standards will be met and followed through the agreed upon terms of issuance of debt. All necessary and basic records relating to the bond transaction (transcript) could include, but are not limited to the following:

- Bond Ordinance
- Bond Counsel Opinion
- Tax Compliance Certificate and Agreement
- Final Official Statement
- Bond Purchase Agreement
- Investments Contracts, GICs, Interest Rate Swaps, Related Bids
- Continuing Disclosure Undertaking or Agreement

3.11.5 Legal

The District will adhere to all State and Federal laws, any bylaws, resolutions, ordinance, arbitrage laws, and bond covenants agreed upon. The District will promptly refer to general counsel, bond counsel, and/or an independent advisor with inquiries or for any necessary guidance pre and post issuance of debt.

3.11.6 Debit Limits

The District may issue bonds and pledge its property and credit to an amount, including existing principal indebtedness, not exceeding 2.875% of the District's taxable property in the District's boundaries. The District also may not issue bonds or notes where the aggregate outstanding unpaid principal balance exceeds 5.75% for non-referendum or short-term debt. The District is located in a tax cap county which is subject to certain limitation rates.

3.11.7 Disclosure Requirements

To avoid disclosure penalties and possible State or Federal action, the District will adhere to the most current Security and Exchange Commission (SEC) disclosure procedures.

3.11.8 Debt Term Structuring Practice

In structuring issuance of debt, the maximum term must not exceed the useful life of the asset.

3.11.9 Debt Issuance Practice

The issuance of each type of debt may differ and the District will take that into account during the selection process. Selection based on borrowing costs or the interest rate on a bond is an essential factor in determining the selection of a bond. Selection has important implications for both present and future taxpayers over the life of the debt which the District will take into consideration.

3.11.10 Debt Management Practices

GURNEE PARK DISTRICT POLICY MANUAL

The District will work with its financial advisors to determine the need of obtaining a municipal bond rating. This determination will be made singularly as the need for bonds arise and will be made on an issue-by-issue basis. Consideration will be given to the amount of the bond, length of the bond, local financial institutions' willingness to purchase the bond unrated at competitive rates, or any other material factors that would allow the Park Board to make the best fiscal determination on behalf of the public trust.

The District may elect or use *bond insurance* as a risk management tool when taking on significant amounts of debt. This could protect the District's credit rating and possibly lower the amount of interest on the bond sale.

Use of Bond Proceeds on Tax-Exempt Financing (if selected): no more than 5% of the bond proceeds are to finance a public facility that may be used by a non-government trade or business for private business. The bond must pass the private activity bond test. The District will promptly consult with general counsel and/or bond counsel before the sale of bond is finalized for clarification of all current regulations and statutes that may apply. Some exceptions may apply as well.

3.11.11 Conflicts of Interest

The District will adhere by the *General Prohibition – Public Officers Prohibited Activities Act – 50 ILCS 105/3(a)*. A conflict of interest could occur but is not limited to if the interested party has vested interest in the outcome or selection of the issuance of bond debt. All interested parties with a conflict of interest could be asked to be removed from the bond process. The District should contact general counsel and/or bond counsel for the variety of exceptions.

3.11.12 Bond Refinancing

The District will look at its current bond portfolio periodically where regulations and statutes apply that will allow the District to refinance. Refinancing opportunities can save the District and both the present and future taxpayers' money. Illinois law describes the details of this transaction in the *Park District Refunding Bond Act (70 ILCS 1270/0.01, et seq.)*.

3.12 Payment Card Industry (PCI) Data Security Policy

Statement of Purpose

It is the policy of the Gurnee Park District to comply with the Payment Card Industry Data Security Standards (PCI-DSS) for the protection and security of payment card information.

Administration of the Policy

The following items are considered specific guidelines associated with this policy and shall be assigned to corresponding procedures as developed:

- A. In order to minimize risk, only those data elements on the payment card that are needed for District business should be stored.
- B. Access to payment card holder data should be limited to District employees requiring such information to complete assigned job tasks.
- C. Payment card data on an internet-connected computer or processed through the internet, should be protected through a secure network with periodic monitoring of its security.
- D. Paper and electronic media that contain cardholder data should be physically secure and identified as confidential information.
- E. Payment card data on documents should be redacted, if feasible, when no longer needed for District business. Documents with legible payment card data should be destroyed in accordance with the Illinois Records Retention Act with appropriate security handling.
- F. Security awareness training should be provided for District employees involved in payment card processing.
- G. The District should assure that its relationships with payment card service providers comply with PCI-DSS.
- H. The Executive Director should be promptly notified of any information security breach.

3.13 Contracts Policy

Statement of Purpose

It is the intent of the Gurnee Park District to set standards for entering into contractual agreements for the purchase of equipment, supplies, and service that cannot be otherwise be provided by internal resources.

Administration of the Policy

Definitions

The following words, terms, phrases and their derivatives shall have the meanings set forth on this section. When not inconsistent with the context, the present tense shall include the future tense; the plural shall include the singular number and the singular number shall include the plural number.

"Concession Contract" means an agreement between the Gurnee Park District and a provider of goods or services that such provider will offer those goods or services for sale to park patrons at park locations.

"Construction Contract" means that a contract for construction, repair, improvement or demolition of any building, bridge, roadway, sidewalk, or other structure or infrastructure, or any work site, grading or planting.

"Contract" means any contract, construction contract, purchase order, agreement or request for proposal (other than a concession contact, lease of real property or collective bargaining agreement) awarded by any officer or agency of the Gurnee Park District or whose cost is to be paid from funds belonging to or administered by the Gurnee Park District regardless of source.

"Contractor" means any person or business entity that shall bid on, submit a proposal for or enter into a contract with the Gurnee Park District, and includes all partners and all joint venturers of such person or business entity.

"Offerors" means only those businesses submitting proposals that are acceptable or potentially acceptable.

"Opening" means the date set for opening of bids, or receipt of proposals in competitive sealed proposals.

"Professional services" means services in any occupation requiring advances or specialized education, training, scientific knowledge or professional skill including without limitation law, accounting, insurance, real estate, engineering, medicine, architecture, dentistry, banking, finance, public relations, education, artists or management.

GURNEE PARK DISTRICT POLICY MANUAL

3.13.1 Power to Contract

A. Executive Director

1. Contracts Not Exceeding the Amount Specified in the Park Code.

The Executive Director shall have the authority to enter into and make all expenditures, approve all change orders, and reject all bids on contracts for labor, services, work, property, material and supplies for the use of the District the expense for which does not exceed the competitive bidding threshold amount established by the Park District Code as specified in 70 ILCS 1205/8-1(c). Purchases under the amount specified in 70 ILCS 1205/8-1(c) but over \$5,000 must be approved by the Executive Director. Purchases under \$5,000 may be approved by Department heads or other designated employees per the Purchasing Policy.

2. Construction Contracts; Work Stoppage.

The Executive Director, with the written approval of the President, shall have the authority to make all expenditures for, enter into, and approve all construction contract change orders, expenditures for which do not exceed ten thousand dollars, if such change order is necessary to avoid a work stoppage on a construction project, delay of which could result in additional costs to the District. Change orders approved pursuant to this subsection shall be reported to the Board at its next meeting.

3. Contingent Contracts.

The Executive Director, with written approval of the President, shall have the authority to enter into any contract in which the fees earned by the Contractor are contingent upon either revenue generated by the Contractor or any cost savings to the District.

B. The Board

Except where the Executive Director has been given the authority to enter into contracts, approve expenditures and reject bids in section 3.14.1 A 1. above, the Board shall have the duty, responsibility and power to enter into all contracts, make all expenditures, approve all change orders and reject bids. All purchases approved by the Board for supplies, equipment and services shall be ordered using a purchase order, except for purchases involving utilities, bonds, tax warrants, evidences of indebtedness, magazines, books, periodicals and contractual services of individuals possessing professional skills, such as architects, lawyers, accountants and engineers.

GURNEE PARK DISTRICT POLICY MANUAL

3.13.2 Selection of Contractors

3.14.2.1 Competitive Bids

A. Purchases of More than \$2,500, But Not Exceeding the Amount Specified in Section 8-1(c) of the Park Code (70 ILCS 1205/8-1(c))

All purchases or contracts involving an expenditure of more than two thousand five hundred dollars, but not exceeding the competitive bidding threshold amount as specified in the Park Code pursuant to 70 ILCS 1205/8-1(c) shall be let on more than one written quotation, and on not less than three competitive written quotations, whenever possible, except in those cases in which the Executive Director shall determine that only one written quotation can be obtained or that no benefit shall inure to the District by obtaining more than one written quotation. Insofar as it is practical for the purchase of supplies, services or construction above five hundred dollars, no less than three persons shall be solicited to submit written quotations that are recorded and placed in the procurement file. Award shall be made to the person offering the lowest responsible quotation after considering the requirements for the contract including but not limited to past performance, testing, quality, workmanship, delivery, and suitability for a particular purpose. The names of the businesses submitting written quotations and the date and amount of each written quotation shall be recorded as a public record.

B. Contracts Exceeding the Amount Specified in the Park Code pursuant to 70 ILCS 1205/8-1(c)

1) Competitive Sealed Bids Required.

All contracts for labor, services, work, property, material and supplies for the use of the District, the expense of which will exceed twenty five thousand dollars, except as is otherwise provided herein, shall be let upon advertisement for sealed bids, to the bidder regarded as being the lowest responsible bidder, considering conformity with specifications, terms of delivery, quality and serviceability. In conjunction with this bidding process, no person shall engage in criminal contracting activity as defined in Illinois law, 720 ILCS 5/33E-1 *et seq.*

2) Competitive Sealed Bids Not Required.

The provisions of this section requiring advertisement and competitive bidding shall not in any event apply to contracts involving:

- a) Contracts which by their nature are not well adapted to competitive bidding, as established by the legislative finding of the Board of Commissioners;

GURNEE PARK DISTRICT POLICY MANUAL

- b) the services of individuals possessing a high degree of professional skill where the ability or fitness of the individual plays an important part;
- c) the printing of finance committee reports and department reports;
- d) the printing or engraving of bonds, tax warrants and other evidence of indebtedness;
- e) utility services, such as water, light, heat, telephone or telegraph;
- f) the use, purchase, delivery, movement or installation of data processing equipment, software;
- g) telecommunications and interconnect equipment, software or services;
- h) duplicating machines and supplies;
- i) goods or services procured from another governmental agency;
- j) equipment previously owned by some entity other than the District itself;
- k) the purchase of magazines, books, periodicals, pamphlets and reports;
- l) emergency acquisition of services or personal property, provided such expenditures are approved by three-fourths of the members of the Board; and
- m) any other service or product otherwise exempted by statute.

C. Invitation for Bids.

In each case the invitation for bids shall be in such form as shall be prescribed by the Executive Director. The invitation for bids shall be published once at least ten days before the day set for receiving bids, in one or more newspapers published in the area of the District. If there is no newspaper published in the area of the District, the notice must appear in a newspaper of general circulation in the area of the District. When deemed expedient, further publications may be ordered by the Executive Director in technical publications. The invitation for bids shall include the following:

- 1) instructions and information to bidders concerning the bid submission requirements, including the time and date set for receipt of such bids, the address of the office to which bids are to be

GURNEE PARK DISTRICT POLICY MANUAL

delivered, the maximum time for bid acceptance by the District, and any other special information;

- 2) the purchase description, evaluation factors, delivery or performance schedule, and such inspection and acceptance requirements as are not included in the purchase description; and
- 3) the contract terms and conditions, including warranty and bonding or other security requirements, as applicable.

D. Evaluation Criteria.

The invitation for bids shall set forth any evaluation criterion to be used in determining product acceptability. It may require the submission of bid samples, descriptive literature, technical data, or other material. The invitation for bids may also provide for accomplishing any of the following:

- 1) inspection or testing of a product prior to award for such characteristics as quality or workmanship;
- 2) examination of such elements as appearance, finish, taste, or feel; or
- 3) other examinations to determine whether the product conforms with any other purchase description requirements.

E. Pre-Bid Conferences.

Pre-bid conferences may be conducted to explain the procurement requirements. Such conferences shall be announced to all prospective bidders known to have received an invitation for bids. Nothing stated at the pre-bid conference shall change the invitation for bids unless a change is made by written amendment. A summary of the conference shall be supplied to all those prospective bidders known to have received an invitation for bids. If a transcript is made, it shall be a public record.

F. Amendments to Invitations for Bids.

- 1) Amendments to invitations for bids shall be identified as such and shall require that the bidder acknowledge receipt of all amendments issued. The amendment shall reference the portions of the invitation for bids it amends. Amendments shall be used to:
 - a) make any changes in the invitation for bids such as changes in quantity, purchase descriptions, delivery schedules, and opening dates;
 - b) correct defects and ambiguities; or
 - c) furnish to other bidders information given to one bidder if such information will assist the other bidders in submitting bids or if the lack of such information would prejudice the other bidders.

GURNEE PARK DISTRICT POLICY MANUAL

- 2) Amendments shall be sent to all prospective bidders known to have received an invitation for bids. Amendments shall be distributed within a reasonable time no less than five working days prior to the opening to allow prospective bidders to consider them in preparing their bids. If the time and date set for receipt of bids will not permit such preparation, such time shall be increased to the extent possible in the amendment or, if necessary, by telegram or telephone and confirmed in the amendment.

G. Modification or Withdrawal of Bid Prior to Opening.

Bids may be modified or withdrawn by notice received by the Executive Director prior to the time and date set for bid opening. An electronic or facsimile transmission modifying or withdrawing the bid received by the Executive Director prior to the time and date set for bid opening will be effective. If a bid is withdrawn in accordance with this section, the bid deposit, if any, shall be returned to the bidder. All documents relating to the modification or withdrawal of bids shall be made a part of the appropriate procurement file. A bidder may correct mistakes discovered before the time and date set for bid opening by withdrawing or correcting the bid, in accordance with the provision of this chapter.

H. Bid Deposits-Required.

- 1) Amount.

In each case, bids will be accompanied by deposits in accordance with the following scale, except as provided in Section 3.14.2.1 I.

- a) If the estimated cost of the improvement or work to be done or the materials or supplies to be furnished totals an aggregate amount less than five million dollars, the amount of the deposit shall be five percent of the total aggregate amount.
- b) If the estimated cost of the improvement or work to be done or the material or supplies to be furnished totals an aggregate amount of more than five million dollars, but less than fifteen million dollars, then the amount of the deposit shall be four percent of the total aggregate amount.
- c) If the estimated cost of the improvement or work to be done or the material or supplies to be furnished totals an aggregate amount in excess of fifteen million dollars then the amount of the deposit shall be three percent of the total aggregate amount.

- 2) Form and Forfeiture.

Such bid deposit shall be in the form of money, cashier's check issued by a bank in good standing, a certified check drawn on a bank in good standing payable to the order of the District, or a bid bond executed by a surety satisfactory to the Executive Director, and shall be forfeited to the District in the event the bidder shall neglect or refuse to enter into a

GURNEE PARK DISTRICT POLICY MANUAL

contract and give bond, as hereinafter required, to execute the work or furnish the materials or supplies for the price mentioned in their bid and according to the plans and specifications in case the contract shall be awarded to the bidder.

I. Bid Deposits Not Required.

Bid deposits shall not in any event be required for the following classes of contracts except that a bid deposit may be required for any contract, including the classes of contracts specified herein, upon the determination of the Board that time of delivery or such other critical circumstances warrants the imposition of a bid deposit requirement:

- 1) contracts for the purchase of standard manufactured motor vehicles;
- 2) contracts for replacement parts or services for equipment that depend upon requirements;
- 3) contracts for materials or supplies the expense of which does not exceed fifty thousand dollars; or
- 4) contracts for construction or services the expense of which does not exceed twenty-five thousand dollars.

J. Bid Opening.

All bids shall be received by the Executive Director. Each bidder shall receive three days' notice of the time and place of the bid opening. Bids shall be opened publicly by a Board member or a District employee in the presence of one or more witnesses at the time and place designated in the invitation for bids. The amount of each bid, and such other relevant information as may be specified by regulation, together with the name of each bidder shall be announced and recorded; the record and each bid shall be open to public inspection.

K. Late Bids, Modification and Withdrawals After Bid Opening.

After bid opening, no changes in bid prices or other provisions of bids prejudicial to the interest of the District or fair competition shall be permitted. Except as otherwise provided by regulation, all decisions to permit the correction or withdrawal of bids, or to cancel awards of contracts based on bid mistakes shall be supported by a written determination made by the Executive Director. Any bid received after the time and date set for receipt of bids is late. Any withdrawal or modification of a bid received after the time and date set for opening of bids at the place designated for opening is late. No late bid, late modification, or late withdrawal will be considered unless received before contract award, and the bid modification, or withdrawal would have been timely but for the action or inaction of District personnel directly serving the procurement activity. Bidders submitting late bids that will not be considered for award shall be so notified as soon as practicable. Records shall be made and kept for each late bid, late modification, or late withdrawal.

GURNEE PARK DISTRICT POLICY MANUAL

1) Minor Informalities.

Minor informalities are matters of form rather than substance evidence from the bid document, or insignificant mistakes that can be waived or corrected without prejudice to other bidders; that is, the effect on price, quantity, quality, delivery, or contractual conditions is negligible. The Executive Director may waive such informalities or allow the bidder to correct them depending on which is in the best interest of the District. Such information may include the failure of a bidder (i) to return the number of signed bids required by the invitation for bids; (ii) sign the bid, but only if the unsigned bid is accompanied by other material indicating the bidder's intent to be bound; or (iii) acknowledge receipt of an amendment to the invitation for bids, but only if it is clear from the bid that the bidder received the amendment and intended to be bound by its terms; or the amendment involved had a negligible effect of price, quantity, quality, or delivery.

2) Mistakes Where Intended Correct Bid is Evident.

If the mistake and the intended correct bid are clearly evident on the face of the bid document, the bid shall be corrected to the intended correct bid and may not be withdrawn. Examples of mistakes that may be clearly evident on the face of the bid document are typographical errors, extending unit prices, transposition errors, and arithmetical errors.

L. Award of Contract.

In determining the trustworthiness and responsibility of bidders, the Board shall consider not only pecuniary ability but also integrity, fitness, capacity, capability and skill necessary to fulfill the terms of the contract faithfully and conscientiously, and to furnish the materials and do the work considered best to meet the requirements of the District. In any case in which the Board shall make a finding that one of several bidders is the lowest trustworthy and responsible bidder there need be no distinct finding or record against any other bidder. Bids shall be unconditionally accepted without alteration or correction, except as authorized in this chapter or by state law. Bids shall be evaluated based on the requirements set forth in the invitation for bids, which may include criteria to determine acceptability such as inspection, past performance, testing, quality, workmanship, delivery, and suitability for a particular purpose. Those criteria that will affect the bid price and be considered in evaluation for award shall be objectively measurable, such as discounts, transportation costs, and total or life cycle costs. No criteria may be used in bid evaluation that is not set forth in the invitation for bids.

M. Single Bid Response.

If only one responsible and trustworthy bidder responds to an invitation for bid an award may be made to that bidder only if the Board finds that the price submitted is fair and reasonable; and

GURNEE PARK DISTRICT POLICY MANUAL

- 1) other prospective bidders had reasonable opportunity to respond;
- 2) there is not adequate time for re-advertisement for bid; or
- 3) the equipment is available only from one source.

N. Tie Bids.

If two or more bids meeting the specifications and other requirements of the Invitation for Bids are tied for low price, the bids will be evaluated based on the following criteria in addition to the criteria described in Section 3.14.2.1 L. ,above.

- 1) If the tie bidders include a bidder or bidders whose principal place of business is located in the District, the District bidder shall be preferred over bidders with their place of business not in the District.
- 2) If the contract cannot be awarded based on Section 3.14.2.1 L. above, the award shall be made by lot to one of the tied bidders unless the Board determines that splitting the award among two or more of the tied bidders is in the best interest of the District. Awards shall be split if all affected bidders agree, if splitting is feasible given the type of good or service requested, and if overall pricing would be significantly lowered balanced against costs of administering multiple contracts or if delivery would be better ensured, or if necessary or desirable to promote future competition.

O. Mistakes Discovered After Award.

Mistakes shall not be corrected after award of the contract except when the Board makes a written determination that it would be unconscionable not to allow the mistake to be corrected. When a bid is corrected or withdrawn, or correction or withdrawal is denied, the Executive Director shall prepare a written determination showing that the relief was granted or denied in accordance with this chapter.

3.13.3 Cancellation or Rejection of Bids

An invitation for bids may be canceled, or any or all bids may be rejected in whole or in part as may be specified in the solicitation, when it is in the best interest of the District in accordance with regulations promulgated by the Executive Director. The reasons for the rejection shall be made part of the contract file. Each solicitation issued by the District shall state that the solicitation may be canceled as provided in this section.

A. Prior to Opening.

- 1) Prior to opening, a solicitation may be canceled by the Board in whole or in part when the Board or Executive Director determine in writing that such action is in the District's best interest for reasons including but not limited to:
 - a) the District no longer requires the supplies, services, or construction;

GURNEE PARK DISTRICT POLICY MANUAL

- b) the District no longer can reasonably expect to fund the procurement; or
 - c) proposed amendments to the solicitation would be of such magnitude that a new solicitation is desirable.
- 2) When a solicitation is canceled prior to opening, notice of cancellation shall be sent to all persons solicited.
- 3) The notice of cancellation shall:
- a) identify the solicitation;
 - b) briefly explain the reason for cancellation; and
 - c) where appropriate, explain that an opportunity will be given to compete on any re-solicitation or any future procurements of similar supplies, services, or construction.

B. After Opening.

- 1) After opening, but prior to award, all bids may be rejected by the Board, in whole or in part, when the Board or Executive Director determine in writing that such action is in the District's best interest for reasons including, but not limited to;
- a) the supplies, services, or construction being procured are no longer required;
 - b) ambiguous or otherwise inadequate specifications were part of the solicitation;
 - c) the solicitation did not provide for consideration of all factors of significance to the District;
 - d) prices exceed available funds and it would not be appropriate to adjust quantities to come within available funds;
 - e) all otherwise acceptable bids, proposals or qualifications received are at clearly unreasonable prices;
 - f) there is reason to believe that the bids or proposals may not have been independently arrived at in open competition, may have been collusive, or may have been submitted in bad faith; or
 - g) that it is otherwise in the best interests of the District to do so.
- 2) A notice of rejection should be sent to all persons that submitted bids, proposals or qualifications.

GURNEE PARK DISTRICT POLICY MANUAL

C. Documentation.

The reasons for cancellation or rejection shall be made a part of the procurement file and shall be available for public inspection.

D. Rejection of Individual Bids, Proposals or Qualifications.

1) General.

This section applies to rejections of individual bids, proposals or qualifications in whole in part.

2) Notice of Solicitation.

Each solicitation issued by the District shall provide that any bid may be rejected in whole or in part when in the best interest of the District.

3) Notice of Rejection.

Upon request, unsuccessful bidders or offerors shall be advised of the reasons therefor.

3.13.4 "All or None" Bids or Proposals

Only when provided by the solicitation may a bid limit acceptance to the entire bid offering. Otherwise, such bids shall be deemed to be non-responsive. If the bid is properly so limited, the District shall not reject part of such bid or proposal and award on the remainder.

3.13.5 Performance Bonds

A. Performance Bonds/Indemnity Agreements in Construction Contracts

Whenever any work for construction or improvement costing over \$50,000 is let by contract, the contractor shall furnish a bond with good sufficient sureties or other acceptable guarantee or insurance in an amount equal to the total amount the District is obligated to pay under such contract, unless a lower amount is fixed by the Board. The bond shall insure faithful performance of the contract in the time and manner prescribed in the contract, but all loss, damages, claims, liabilities, judgments, costs and expenses which may otherwise accrue against the District in consequence of the granting of the contract, or which may in anyway result therefrom or the carelessness or neglect of such contractor, the agents, employees or workperson in any respect whatever. It shall be so conditioned also that when any judgment shall be recovered against the District by reason of carelessness or negligence of such contractor, the agents, employees or workperson, and when due notice of the pendency of such suit has been District to such contractor, such judgment shall be conclusive against such contractor and their obliges under such contract,

not only as to the amount of damages but also to the liability. The bond shall be conditioned further to provide for the payment of all claims and demands whatsoever which may accrue to it and every person who shall be employed by the contractor, or any assignee or subcontractor of such contractor in or about the performance of such contract. The bond shall be conditioned also, for the payment of all claims and demands whatsoever which may accrue to each and every person so employed, or to the beneficiaries of any such person, under any applicable laws relating to compensation to workperson for accidental injuries or death; and said contract shall contain a provision that the contractor shall insure his liability to pay the compensation and shall pay all claims and demands for compensation for accidental injuries or death under the provisions of the Illinois Workers Compensation Act; and also that when any judgment or award of any Board of arbitrators shall be rendered against the District of any suit or claim arising under the aforementioned act, such judgment or award shall be conclusive against such contractor and his/her obliges under the contract, not only as to the amount of damages, but as to their liability. Such contracts shall contain such other conditions and provisions as the Board or Executive Director may deem necessary and proper.

B. Performance Bonds/Indemnity Agreements in Contracts Not Involving Construction

Except in construction contracts, as provided in this Section 3.14.5 A., above, a bond with sufficient sureties or other acceptable guarantee or insurance in such amount as shall be deemed adequate, not only to insure performance of the contract in the time and manner prescribed in the contract, but also to save, indemnify and keep harmless the municipality against all loss, damages, claims, liabilities, judgments, costs and expenses which may in anyway accrue against the District in consequence of the granting of the contract, or which may in anyway result therefrom, may be required when, in the opinion of the Executive Director, the public interest will be served thereby. All contracts and obligations so taken shall be in the name of and run by the District. All contracts and performance bonds or indemnity agreements shall be approved as to legal form by the Executive Director. All performance bonds or indemnity agreements shall be approved as to sufficiency and surety by the Executive Director. The provision of this section requiring performance bonds shall not in any event apply to contracts for the purchase of standard manufactured motor vehicles.

C. Execution of Contracts

All contracts approved by the Board pursuant to section 3.14 shall be executed by the President and attested to by the Secretary on the part of the District. No contract shall be binding upon the District, nor shall any work contracted for, commenced or any materials or supplies be delivered thereunder, until such contract has been duly executed.

D. Certain Rights Reserved by Board

GURNEE PARK DISTRICT POLICY MANUAL

In all contracts executed on behalf of the Board, there shall be reserved to the Board, or its duly authorized representative, the right to decide all questions as to the proper performance of the work, or the quality or quantity of materials or supplies furnishes; and in cases of improper construction or the furnishing of defective material, or the noncompliance with any of the terms and conditions of the contract to declare said contract forfeited, and to re-let the same without re-advertising, and to fix the amount of damages, if any, which the contractor or contractors, failing to properly construct such work, in such cases of default, should pay the District according to the just and reasonable interpretation of such contract.

E. Contractor Liability, Covenants and Conditions to be inserted in Contract

Whenever the District shall let any work or improvement which shall require the digging up, use or occupancy of any public way or other public place of the District, substantial covenants requiring such contractor to put up and maintain such barriers and lights during the nighttime as will effectively prevent the happening of any accident for which the District might be liable in consequence of such digging up, use or occupancy of any public way or other public place, shall be inserted in the contract and also such other covenants and conditions as experience may prove necessary to save the District harmless from damages. Such contract shall provide that the party contracting with the District shall be liable for all damages occasioned by the digging up, use or occupancy of such public way or other public place, or which may result therefrom.

F. Reservation of Payment

On all construction contracts involving periodic payments, a reserve of ten percent of the contract value shall be retained until final completion of the contract.

1. The reserve may be reduced by the Board or the Executive Director for construction contracts where the remaining work is solely after-care landscaping, in which case the reserve shall be equal to ten percent of the value of the landscaping portion of the contract.
2. The reserve may be reduced by the Board or the Executive Director for construction contracts involving an expenditure exceeding \$50,000 where the amount of the value of the remainder work is less than five percent of the whole contract, in which case the reserve may be reduced to an amount equal to double the value of the remaining work, but not less than two percent of the value of the contract.

G. Final Payment

No such payment shall be made unless the money applicable to the payment of such work or contract is available; and the material and supplies have been provided or the work has been performed in

GURNEE PARK DISTRICT POLICY MANUAL

compliance with the terms and conditions of the contract. Final payment shall in no way affect the right of the District to enforce the complete performance of the contract against the contractor or any surety, or to sue for the recovery of damages for failure to do so, nor shall it affect the terms of contractor's guarantee.

H. Failure of Contractor to Pay Subcontractors, Workers and Employees

Every contract shall contain a condition to the effect that it shall and may be lawful for the Board or the Executive Director whenever it shall have reason to believe that the contractor has neglected or failed to pay any subcontractor, workers or employee for work performed on or about any public improvement or other work contracted for, to order and direct that no further payments be made upon such contract until the Executive Director shall be satisfied that such subcontractor, workperson and employees have been fully paid.

I. Notice to Contractor that Vouchers Will Not be Issued Until Subcontractors, Workers and Employees Are Paid; Payment of Subcontractors, Workers and Employees With Moneys Due Contractor

Whenever the Board or the Executive Director shall notify the contractor by notice personally served or by leaving a copy thereof at the contractor's last known place of business, that no further vouchers or estimates will be issued or payments made on the contract until the subcontractors, workers and employees have been paid, and the contractor shall neglect or refuse, for the space of ten days after such notice shall have been served to pay such subcontractors, workers and employees, it shall and may be lawful for the District to apply any money due or that becomes due under the contract to the payment of such subcontractors, workers and employees without other or further notice to said contractor. The failure of the District however, to retain and order or direct that no vouchers or estimates shall issue or further payments be made, shall not, nor shall the paying over of such reserved percentage without such subcontractors, workers or employees being first paid, in any way affect the liability of the contractor, or their sureties, to the District, or to any such subcontractors, workers or employees upon any bond given in connection with such contract.

3.13.6 Concession Contracts

A. Requirement

No person shall operate a business or offer for sale any food, beverage, product, good or service on any District property without having first obtained a concession contract or permit in accordance with the provisions of this Policy.

B. The Goal

GURNEE PARK DISTRICT POLICY MANUAL

The goal of District concession contracts is to provide the highest possible quality and variety of food, commodities and services which will enhance the use of the parks and provide comfort and convenience to patrons at reasonable prices while assuring reasonable revenue to the District and consistency of the concession with current and future District plans for recreation, operations and other activities on District property.

C. Notice of Availability

If the Board determines that there exists an opportunity for a concession on District property, the Board shall publish in a newspaper of general circulation in the District and shall post at the District's main office a notice of such concession opportunity with any deadline for receipt of applications and procedures for filing the application.

D. Preliminary Review of Application

Prior to the Board's consideration of an application or a proposal for a concession, the Executive Director shall review all applications or proposals for concessions and make a recommendation to the Board as to whether the District should enter into a particular concession contract. In determining whether to recommend approval of the application or proposal, the Executive Director shall consider the following matters:

- 1) the qualifications of the applicant, including the applicant's professional qualifications, skills, experience and financial ability;
- 2) the quality, including the creative or innovative nature, of the proposed food, commodity or service;
- 3) the willingness of the applicant to provide the District a percent of gross sales which exceed the guidelines described in this section, below, more than other applicants;
- 4) the extent to which the proposed concession would not interfere with and would enhance the park recreational activities;
- 5) the extent to which the proposed concession is consistent with the historic and aesthetic nature and planned use of the proposed location;
- 6) the extent to which the proposed concession adds to the diversity of the District concession activity;
- 7) whether the applicant has successfully operated and proposed concessions in the past and has complied with applicable ordinances;
- 8) the willingness of the applicant to clean up within one hundred feet of the concession location and to maintain appropriate refuse containers; and
- 9) the willingness of the applicant to wear an approved uniform or insignia to show that the applicant is an approved concessionaire.

GURNEE PARK DISTRICT POLICY MANUAL

E. Power to Contract

After considering the recommendation of the Executive Director, the Board shall decide whether to approve the application or accept the proposal for a concession contract.

F. Concession Contract Requirements

1) Compliance with Laws.

All concessionaires must comply with all applicable federal, state and local laws, ordinances, regulations and rules, including but not limited to compliance with sanitation requirements for sale or service of food of state and local governments.

2) Insurance Requirements.

All concessionaires are required to provide certificates of insurance required by the Executive Director naming the District as additional insured.

3) Concessionaire and Employees.

All concessionaires and its employees, if any, are required to wear during the hours of operation a uniform approved by the Executive Director. A name and an identification number shall appear on the uniform. A concessionaire must submit to the District a current list of employees. A concessionaire must not employ a person under the age of sixteen (16) years for the operation of a District concession.

4) Sales Records.

A concessionaire must maintain adequate sales records of its operation on an ongoing basis. These records shall be subject to inspection by the District at any time. All monthly fees paid to the District shall be accompanied by a standard form sales report which shall be provided to the concessionaire at the beginning of each year.

5) Concession Items.

A concessionaire must submit to the District for its approval a list of every item to be sold and the charge for the item. Additional items may not be sold without written approval of the District.

6) Removal of Trash.

A concessionaire's place of business is to be maintained in a clean orderly manner. All trash and debris resulting from the operation of the concession must be removed. A concessionaire has an obligation examine the

GURNEE PARK DISTRICT POLICY MANUAL

property within one hundred feet of the concession operation to discover and remove any such trash or debris.

7) Returnable, Recyclable and Biodegradable Containers.

A concessionaire selling any food item in or on a container must provide containers which are returnable, recyclable or biodegradable.

8) Posting of Permit, Name, Address and Phone Numbers.

A concessionaire must prominently post at the place of concession operation, the concession permit and the name, address and phone number of the concessionaire and the phone number of the Executive Director.

9) Unauthorized Concessionaires.

If it comes to the attention of a District concessionaire that a person, partnership, corporation or other legal entity is operating a concession without authorization from the District, the concessionaire must notify the District employees immediately.

10) Inspection of Operations and Records.

A concessionaire must submit to inspections of its operations and records upon request by the Executive Director or their authorized representative.

G. Fees and Contract Payments

1) Food Service Concession.

Any concessionaire operating a food service establishment shall pay an annual license fee, if any, as approved by the Board in addition to all other fees.

2) Fee Guidelines.

A concession fee will be established for each concession contract. In approving the fee, the Board shall use the following guidelines. Concession fees which are not consistent with these guidelines may be approved when the Board believes that the public interest would be served by an alternate fee arrangement.

<u>Annual Gross Sales</u>	<u>Food Payment</u>	<u>Non-Food Payment</u>
\$1-\$9,999	10%	15%
\$10,000-\$49,999	12-14%	16-20%
\$50,000-\$99,999	15-19%	21-25%
\$100,000-\$249,000	20-24%	26-30%
Over \$250,000	Over 25%	Over 31%

GURNEE PARK DISTRICT POLICY MANUAL

H. Fines

Each violation of this section shall subject the concessionaire to a civil fine of up to \$1,000. Each day that a violation continues shall be deemed a separate violation.

I. Termination of Concession Permit

The Executive Director may terminate a concession permit if a concessionaire:

- 1) violates a District ordinance on three occasions over a period of one year;
- 2) breaches a term of the concession contract;
- 3) poses a health or safety hazard; or
- 4) refuses to submit to an inspection of operations or records.

3.14 Reimbursement of Employee and Officer Travel, Meal and Lodging Expenses

Purpose

The Gurnee Park District will reimburse employee and officer travel, meal, and lodging expenses incurred in connection with pre-approved travel, meal, and lodging expenses incurred on behalf of the Gurnee Park District. Employees and officers are expected to exercise the same care in incurring expenses for official business as a prudent person would in spending personal funds.

Definitions

"**Entertainment**" includes, but is not limited to, shows, amusements, theaters, circuses, sporting events, or any other place of public or private entertainment or amusement, unless ancillary to the purpose of the program or event.

"**Travel**" means any expenditure directly incident to official travel by employees and officers of the Gurnee Park District or by wards or charges of the Gurnee Park District involving reimbursement to travelers or direct payment to private agencies providing transportation or related services.

3.14.1 Authorized Types of Official Business

Travel, meal and lodging expenses shall be reimbursed for employees and officers of the Gurnee Park District only for purposes of official business conducted on behalf of the Gurnee Park District, which includes but is not limited to off-site or out-of-town meetings related to official business and pre-approved seminars, conferences and other educational events related to the employee's or officer's official duties.

3.14.2 Maximum Allowable Expenses

The Maximum allowable expenses related to travel, meal and lodging for employees and officers of the Gurnee Park District incurred while conducting official business on behalf of the Gurnee Park District are defined below.

Airfare – Travelers are expected to obtain the lowest available airfare that reasonably meets business travel needs. Travelers are encouraged to book flights at least thirty (30) days in advance to avoid premium airfare pricing. Only coach or economy tickets will be paid or reimbursed. The traveler will pay for the difference between higher priced tickets and coach or economy tickets with their own personal funds. For assistance with airfare arrangements contact the Business Services Department.

Personal Automobiles – Mileage reimbursement will be based on mileage from the work location office to the off-site location of the official business, not from the employee's or officer's residence. When attending a training event or other off-site official business directly from an employee's or officer's residence, no reimbursement will be made if the distance is less than the mileage of a normal commute to the workplace. If the distance is higher than the employee's or officer's normal commute, reimbursement will be paid based on the differential of the commute less the mileage of a normal commute to the workplace. An employee or officer will be reimbursed at the prevailing IRS mileage rate. The traveler will only be reimbursed up to the price of a coach airfare ticket if they drive to a location for which airfare would have been less expensive.

GURNEE PARK DISTRICT POLICY MANUAL

Automobile Rentals – Travelers will be reimbursed for the cost of renting an automobile including gasoline expense only as limited in this section. Travelers using rental cars to conduct official business are required to purchase insurance through the rental agency. Compact or mid– size cars are required for two or fewer employees or officers traveling together and a full– size vehicle may be used for three or more travelers. The traveler must refuel the vehicle before returning it to the rental company.

Public Transportation – In the case of local training or official business where an employee or officer chooses to use public transportation, reimbursement for use of public transportation is based on mileage from the agency office to the training site (not from the traveler’s residence), regardless of the transportation method chosen. When attending training or business directly from an employee’s or officer’s residence, no reimbursement will be made if the distance is less than the mileage of a normal commute to the workplace. If the distance is higher than the traveler’s normal commute, reimbursement will be paid at the differential of the commute less the mileage of a normal commute to the workplace.

Other Transportation – The traveler should utilize hotel shuttle service or other shuttle services, if available. If none are offered, the use of the most economic transportation is encouraged.

Hotel/Motel Accommodations – The traveler will be reimbursed for a standard single-room at locations convenient to the business activity. Employees may be requested to share room when possible. In the event of a change in plans or a cancellation, the traveler must cancel the hotel/motel reservation so as not to incur cancellation charges. Cancellation charges will not be reimbursed by the District unless approved by a vote of the Board of Commissioners of the Gurnee Park District.

Meals - Meal reimbursement is limited to the current daily U.S. General Services Administration (GSA) regulations in place at the time the expense is occurred. Please contact the Business Services Department for assistance with determining this amount.

Prior approval by the Executive Director of the Gurnee Park District is required for per diem allowances. Elected officials shall not receive per diem allowances but shall be eligible for reimbursement of expenses consistent with this policy. Meals provided by the conference or seminar should be deducted from the per diem allowance. Partial reimbursement may be made for departure and return days based on time.

Vacation in Conjunction with Business Travel – In cases where vacation time is added to a business trip, any cost variance in airfare, car rental, lodging and/or any other expenses must be paid by the traveler.

Accompanied Travel – When a traveler is accompanied by others not on official business, any lodging, transportation, meals or other expenses above those incurred for the authorized traveler will not be reimbursed by the Gurnee Park District.

Parking – Parking fees at a hotel/motel will be reimbursed only with a receipt.

Payment for expenses over the maximum allowable amount as described above may be the responsibility of the employee.

GURNEE PARK DISTRICT POLICY MANUAL

3.14.3 Approval of Expenses

Travel, meal, and lodging expenses incurred by any employee in excess of the maximum allowable amount defined in Section D of this Policy, must be approved in an open meeting by a majority roll-call vote of the Board of Commissioners of the Gurnee Park District. Travel, meal, and lodging expenses incurred by any member of the Board of Commissioners of the Gurnee Park District must be approved by roll call vote at an open meeting of the governing board or corporate authorities of the local public agency.

3.14.4 Documentation of Expenses

Requests for attendance at overnight conferences, seminars, courses, meetings and other educational opportunities (collectively, "training program") must be approved by the Executive Director prior to attending same via the Gurnee Park District Employee and Officer Travel, Meal and Lodging Expense Form (Exhibit A) which will contain the following information:

- 1) the cost of travel, meals, or lodging.
- 2) the name of the individual who is requesting the travel, meal, or lodging expense;
- 3) the name of the individual completing the form, if different than the individual requesting to attend the conference.
- 4) the title of the training program.
- 5) the job title or office of the individual who is requesting the travel, meal, or lodging expense; and
- 6) the date or dates and nature of the official business for which the travel, meal, or lodging will be expended.

Any requests for attendance at training programs lasting five days or longer must also be approved by the Board of Park Commissioners.

All documents and information submitted under this Section are public records subject to disclosure under the Freedom of Information Act.

The Board of Commissioners of the Gurnee Park District hereby adopts as its official standardized form for the request to attend an overnight training program the Gurnee Park District Employee and Officer Travel, Meal and Lodging Expense form attached hereto and incorporated as Exhibit A.

3.14.5 Entertainment Expenses

No employee or officer shall be reimbursed for any entertainment expense, unless ancillary to the purpose of the program, event or other official business.

GURNEE PARK DISTRICT POLICY MANUAL

EXHIBIT A

GURNEE PARK DISTRICT
EMPLOYEE AND OFFICER TRAVEL, MEAL AND LODGING EXPENSE FORM

PROCEDURE

- 1 This form is to be used for attendance and expense approval at overnight conferences, seminars, courses, meetings and other educational opportunities ("training program").
- 2 Please complete entire form, including your signature.
- 4 After Department Head approval, forward to the Executive Director at least 4 weeks prior to the training program (longer if air arrangements must be made).
- 5 Conferences five (5) days or longer must be pre-approved by the Park Board. Notify the Executive Director at least eight weeks prior to the conference so the request is added to the Park Board agenda. Packets go out the Thursday prior to the 3rd Tuesday of the month.
- 6 Please refer to the Policy Governing Reimbursement of Employee and Officer Travel, Meal and Lodging Expenses for additional details regarding training program attendance.

Individual Attending Training Program (First Last): _____ Title: _____

Employee Completing Form (if different than above): _____ Date: _____

Training Program Title: _____ Location: _____

Dates Attending (mm/dd/yyyy): _____

G/L Code for this trip: _____ Amount Budgeted for this conference: _____

Your Total Trip Expenses:

Registration Fee* \$ _____

Travel** \$ _____

_____ miles x IRS Rate or airfare

Hotel*** \$ _____

(# of nights x rate + parking if applicable)

Sharing room (Y/N) _____ N _____

Roommate: _____

Car Rental**** \$ _____

Meals & Incidental \$ _____ 0.00

Please complete the Meal and Incidental Allowance Calculation and include with submission.

Total \$ _____ 0.00

Per Diem Check Request:	
Meals & Incidental	\$ _____ 0.00
Check to be ready on:	(date)

* Registration Fee should be paid by Park District Poard or AP Check.

** Airline tickets should be purchased with Park District PCard. For mileage reimbursement, use mileage reimbursement form.

*** Hotel rooms should be reserved and paid for with Park District Poard. If sharing a hotel room, the individual paying for the room will include the full amount on his/her form.

**** Car Rental should be reserved and paid for with Park District Poard.

Please provide a brief description of the official business purpose of this training program:

Employee Signature: _____ Date: _____

Department Head Approval: _____ Date: _____

Executive Director Approval: _____ Date: _____

GURNEE PARK DISTRICT POLICY MANUAL

Gurnee Park District
Conference Meal and Incidental Allowance Calculation

Name of Attendee	_____	0
Name of Conference	_____	0
Location of Conference	_____	0
Dates of Conference	_____	1/0/1900
Arrival Date & Beginning Time of Trip	_____	
Departure Date & End Time of Trip	_____	

For daily meal and incidental rates, please use www.gsa.gov. Rates can be found under Travel tab. Meals included as part of the conference registration should be entered as \$0 below. First day, travel beginning after 10am do not included breakfast. Last day, travel ending before 5:00pm do not include dinner.

		Per Item Allocation
Day one: <u>6/5/2022</u>	Breakfast	
	Lunch	
	Dinner	
	Incidental.*	
Day two: <u>6/6/2022</u>	Breakfast	
	Lunch	
	Dinner	
	Incidental.*	
Day three: <u>6/7/2022</u>	Breakfast	
	Lunch	
	Dinner	
	Incidental.*	
Day four: <u>6/8/2022</u>	Breakfast	
	Lunch	
	Dinner	
	Incidental.*	

Total Allowance for conference: \$ -

*Incidental includes tips, taxis, coat check, etc.

SECTION 4 RECREATION POLICIES

4.1 Employees with Chronic Infectious Diseases

Statement of Purpose

Employees with identified chronic infectious diseases shall be permitted to retain their positions whenever, through reasonable accommodation, their employment does not constitute a direct threat to the health or safety of themselves or others and the employee is able to satisfactorily perform the essential functions of his job. Such employees shall remain subject to the District employment policies and procedures; including, but not limited to; sick leave, physical examinations, temporary and permanent disability and termination.

Administration of the Policy

Employment decisions will be made in accordance with applicable law and in conjunction with current, available public health department guidelines concerning the particular disease in question. Individual cases will not be prejudged; rather, decisions will be made based upon the facts of the particular case. The determination of an employee's continued employment status will be made in accordance with procedures implemented by the District. Employees with chronic infectious diseases shall maintain all rights, privileges and services provided by law and the policies and procedures of the District.

The District shall respect the right to privacy of any employee who has a chronic infectious disease. Subject to applicable law, the employee's medical condition shall be disclosed only to the extent necessary to avoid a health or safety threat to the employee and others. The number of personnel aware of the employee's medical condition will be kept at the minimum needed to assure proper care of the employee and to detect situations in which the potential for transmission may increase. Persons deemed to have "a direct need to know" will be provided with the appropriate information and will be made aware of confidentiality requirements.

Note: Bloodborne Pathogen and Infectious Disease Guidelines are included in the Employee Personnel Policy Manual in Appendix E.

4.2 Participants with Chronic Infectious Diseases

Statement of Purpose

Participants with identified chronic infectious diseases may attend District programs whenever, through reasonable accommodation, their attendance does not constitute a direct threat to the health or safety of themselves or others.

Administration of the Policy

Decisions will be made in accordance with applicable law and in conjunction with current, available public health department guidelines concerning the particular disease in question. Individual cases will not be prejudged; rather, decisions will be made based upon the facts of the particular case.

The determination of whether a participant with a chronic infectious disease may attend District programs shall be made in accordance with procedures implemented by the District. Participants with chronic infectious diseases shall maintain all rights, privileges and services provided by law and the policies and procedures of the District.

The District shall respect the right to privacy of any participant who has a chronic infectious disease. Subject to applicable law, the participant's medical condition shall be disclosed only to the extent necessary to avoid a health or safety threat to the participant and others. The number of personnel aware of the participant's condition will be kept at the minimum needed to assure proper care of the participant and to detect situations in which the potential for transmission of the disease may increase. Persons deemed to have "direct need to know" will be provided with the appropriate information and will be made aware of confidentiality requirements.

Note: Bloodborne Pathogen and Infectious Disease Guidelines are included in the Employee Personnel Policy Manual in Appendix E.

4.3 Mobility Device Use Policy

Statement of Purpose

This policy is enacted to comply with the terms and conditions of Title 2 of the Americans with Disabilities Act of 1990 and avoid unreasonable discrimination in the provision of public services and benefits against persons with mobility disabilities.

Administration of the Policy

Definitions

“**Direct threat**” means a significant risk to the health or safety of others that cannot be eliminated by a modification of policies, practices or procedures, or by the provision of auxiliary aids or services.

“**Executive Director**” means the chief administrative officer of the Gurnee Park District, or his/her designee.

“**Electronic personal assistance mobility devices (EPAMDs)**” means a Segway® PT, or a battery-powered mobility device with substantially similar characteristics and functionality.

“**Other Power-Driven Mobility Device**” means any mobility device powered by batteries, fuel, or other engines—whether or not designed primarily for use by individuals with mobility disabilities—that is used by individuals with mobility disabilities for the purpose of locomotion, but that is not a wheelchair within the meaning of this Policy.

“**Qualified individual with a disability**” means an individual with a disability who, with or without reasonable modifications to rules, policies, or practices, the removal of architectural, communication, or transportation barriers, or the provision of auxiliary aids and services, meets the essential eligibility requirements for the receipt of services or the participation in programs or activities provided by a public entity.

“**Wheelchair**” means a manually-operated or power-driven device designed primarily for use by an individual with a mobility disability for the main purpose of indoor, or of both indoor and outdoor locomotion.

4.3.1 Mobility assistance devices.

- A. Use of wheelchairs and manually-powered mobility aids. The District shall permit individuals with mobility disabilities to use wheelchairs and manually-powered mobility aids, such

as walkers, crutches, canes, braces, or other similar devices designed for use by individuals with mobility disabilities, in any areas open to pedestrian use.

- B. Use of Other Power-Driven Mobility Devices.

- 1) Permitted users. Only individuals with mobility disabilities may use Other Power-Driven Mobility Devices in areas designated by the Executive Director within District facilities or on District property.

GURNEE PARK DISTRICT POLICY MANUAL

- a. The District shall not ask an individual using a wheelchair or Other Power-Driven Mobility Device questions about the nature and extent of the individual's disability.
 - b. The District may ask a person using an Other Power-Driven Mobility Device to provide a credible assurance that the mobility device is required because of the person's disability. Credible assurance shall include: a valid, State-issued, disability parking placard or card, or other State-issued proof of disability; or a verbal representation, not contradicted by observable fact, that the Other Power-Driven Mobility Device is being used for a mobility disability. A "valid" disability placard or card is one that is presented by the individual to whom it was issued and is otherwise in compliance with the State of issuance's requirements for disability placards or cards.
- 2) Permitted Other Power-Driven Mobility Device. Only EPAMDs are permitted to be operated in District facilities or on District property. No combustion engine-powered Other Power-Driven Mobility Devices are allowed to be operated in District facilities or on District property.
 - 3) Variances. The Executive Director may grant a qualified individual with a disability a variance to allow a combustion engine-powered Other Power-Driven Mobility Device only at an outdoor facility owned and operated by the District upon a showing that (a) application of this restriction would cause an undue hardship on the applicant, and (b) emissions from the combustion engine-powered Other Power-Driven Mobility Device shall not have a deleterious impact on the health and safety other District patrons participating in or observing the relevant activity, service or program. Applications for a variance must be received by the Director at least 48 hours in advance of the relevant program, activity or service to which it shall apply, or the first in a series thereof.

4.3.2 Safety.

- A. General Safety Regulations. An Other Power-Driven Mobility Device:
 - 1) is allowed in any area of a facility or park in which the general public is allowed, with the exception of stairways and identified hazardous areas;
 - 2) must be controlled by the person riding the device;
 - 3) must be operated in compliance with the following guidelines:
 - a) may not exceed 4 mph in an indoor facility or 6 mph at an outdoor park or facility;
 - b) shall be driven on the right side of the circulation route;
 - c) the total combined height of the EPAMD and the operator may not exceed the height of the lowest immovable building element or park feature located in the area such device is to be operated;

GURNEE PARK DISTRICT POLICY MANUAL

- d) is prohibited from carrying another person on the frame, or any object on the frame that may make the EPAMD less stable;
- e) may not be driven into wet or ecologically sensitive areas which are posted as prohibited areas by the District; and
- f) may not be operated in a dangerous or reckless manner that jeopardizes the safety of the operator, District employees, or District participants.

B. Notwithstanding the general safety regulations described above, the Executive Director shall have authority to direct a qualified individual with a disability on the safe operation of a permitted Other Power-Driven Mobility Device in light of the existing conditions at the facility where such individual seeks to operate the device and actual perceived risks related thereto, but not mere speculation, stereotypes, or generalizations about individuals with disabilities. In giving direction on the safe operation of a permitted Other Power-Driven Mobility Device, the Executive Director may consider the then existing uses at the facility, the volume of pedestrian traffic, the prevailing environmental conditions, the density and placement of stationary devices and the individual's experience with the operation of such device.

C. This policy does not require the District to permit an individual to participate in or benefit from the services, programs, or activities of the District when that individual poses a direct threat to the health or safety of others. The Director has authority to prohibit an individual from participating in or benefiting from the services, programs, or activities of the District when that individual poses a direct threat to the health or safety of others. In determining whether an individual poses a direct threat to the health or safety of others, the Director must make an individualized assessment, based on reasonable judgment that relies on current medical knowledge or on the best available objective evidence, to ascertain: the nature, duration, and severity of the risk; the probability that the potential injury will actually occur; and whether reasonable modifications of policies, practices, or procedures or the provision of auxiliary aids or services will mitigate the risk.

4.3.3 Personal devices and services

This Policy does not require the District to provide to individuals with disabilities personal devices, such as wheelchairs or permitted Other Power-Driven Mobility Devices.

4.3.4 Notice

The District shall make available to applicants, participants, beneficiaries, and other interested persons, information regarding the provisions of policy and its applicability to the services, programs, or activities of the District in a manner designed to apprise such persons of the protections against discrimination assured them by the Act and this policy.

4.3.5 Miscellaneous

A. The District accepts no responsibility for storage of any mobility device.

GURNEE PARK DISTRICT POLICY MANUAL

- B. The District accepts no liability for damage to any mobility device, or injury to the operator, whether caused by the operator, another visitor to a District facility or site, the physical conditions of the District facility or site, or any other circumstance.
- C. The District accepts no liability for damage caused by the operator of the device, or injury to others caused by the operator of the device.
- D. The District accepts no liability for any injuries or property damage, to either the operator or others, resulting from the District's failure to enforce this policy or to supervise the operator of an Other Power-Driven Mobility Device.
- E. The District reserves the right to change, modify, or amend this policy at any time.

4.4 Service Animal Policy

Statement of Purpose

The purpose of this policy is to comply with terms and conditions of Title 2 of the Americans with Disabilities Act of 1990 and avoid unreasonable discrimination in the provision of public services and benefits against persons with disabilities who have service animals.

Administration of the Policy

4.4.1 Primary District Contacts

Participants and authorized users may request to have a service animal accompany them in parks and facilities where they are authorized users as a reasonable accommodation. Persons with disabilities are invited to contact the District ADA Coordinator Kraig Owens at 847-599-3763 or kowens@gurneeparkdistrict.com.

Employees may request to have a service animal as a workplace accommodation. Please contact Kraig Owens, ADA Coordinator, for information regarding this process.

Visitors may be accompanied by a service animal when observing programs and activities, or enjoying Agency parks and facilities, without making a request for a reasonable modification. Persons with disabilities are invited to contact the ADA Coordinator Kraig Owens at 847-599-3763 or kowens@gurneeparkdistrict.com with any questions about this policy.

4.4.2 Definitions

- A. **Service Animal:** A *dog* or a *miniature horse* that has been individually trained to perform tasks for the benefit of a person with a disability. Exceptions may be made by the Agency on a case-by-case basis in accordance with the law. Tasks may include, but are not limited to, guiding individuals with impaired vision, alerting individuals with impaired hearing to sounds, pulling a wheelchair, or retrieving dropped items. Dogs or miniature horses that are not trained to perform tasks that mitigate the effects of a disability, including dogs or miniature horses that are used purely for emotional support, are not considered service animals and are not allowed at District facilities and premises, unless otherwise specifically permitted, such as at a dog park or equestrian facility.
- B. **Partner/Handler:** A person with a disability who uses a service animal as a reasonable accommodation, or a trainer.
- C. **Team:** A partner/handler and a service animal. The two work as a cohesive team in accomplishing the tasks of daily living.
- D. **Trainee:** A dog or a miniature horse being trained to become a service animal has the same rights as a fully trained service animal when accompanied by a partner/handler and identified as such.

GURNEE PARK DISTRICT POLICY MANUAL

4.4.3 General Rule Regarding Service Animals

As a general rule, the District will modify policies, practices, and procedures to permit the use of a service animal by an individual with a disability.

4.4.4 Restrictions/Areas of Safety

The District may impose some restrictions on service animals for safety reasons. Restrictions are considered individually to determine if the animal poses a danger to others at the District's sites, or could be in danger itself, and to determine if other reasonable modifications can be provided to assure that the individual enjoys access to the premises, facility, services or programs. Questions about restrictions on service animals should be directed to the contacts listed in Section II.

4.4.5 Responsibilities of Partner/Handler

A Partner/Handler is responsible for the following:

- A. Responding truthfully to the limited and appropriate inquiries that may be made by employees regarding the service animal.
- B. Ensuring that the animal meets any local licensing requirements, including maintenance of required immunizations for that type of animal.
- C. Service animals are required to wear a license and/or tag at all times.
- D. Partners/handlers must ensure that the animal is in a harness or on a leash or tether at all times. Exceptions may be considered individually.
- E. Partners/handlers must ensure that the animal is under control and behaves properly at all times. The supervision of the animal is solely the responsibility of its partner/handler. If the animal's behavior becomes a hygiene problem, or the animal acts in a threatening manner, the District may require the partner/handler to remove the service animal from the site.
- F. Partners/handlers must ensure that all local ordinances or other laws regarding cleaning up after the animal urinates and/or defecates are strictly adhered to. Individuals with disabilities who physically cannot clean up after their own animals are not required to clean or pick up and dispose of urine and/or feces; however, these individuals should use marked service animal toileting areas where provided.

GURNEE PARK DISTRICT POLICY MANUAL

- G. Partners/handlers must keep the service animal in good health. If the service animal becomes ill, the partner/handler must remove it from the area. If such action does not occur, District staff may require it to leave.
- H. The District may exclude a service animal from all parts of its property if a partner/handler fails to comply with these restrictions, and in failing to do so, fundamentally alters the nature of programs, services, or activity offered by the District.
- I. The District may exclude a service animal from all parts of its property if a partner/handler fails to control the behavior of a service animal and it poses a threat to the health or safety of others.

4.4.6 Requirements for Agency Employees, Participants and Authorized Users, and Visitors

Members of the Agency staff, participants and authorized users, and visitors on District property, are responsible for the following:

- A. Allow service animals to accompany the partner/handler at all times and anywhere at a site except where animals are specifically prohibited, such as at a zoo.
- B. Refrain from distracting a service animal in any way. Do not pet, feed, or interact with the animal without the partner/handler's invitation to do so.
- C. Shall not separate a partner/handler from a service animal.
- D. The District may take disciplinary action against any individual who fails to abide by these guidelines.

4.4.7 Temporary Exclusion of Service Animals

A participant or authorized user, employee, or visitor may report a concern regarding a service animal to the District's ADA Coordinator or other supervisory staff.

- A. Temporary Exclusion of a Service Animal Used by a Participant or Visitor:
 - 1) In response to an immediate concern, authorized District staff may determine that a service animal must be temporarily removed from parks, sites, or facilities. The employee authorized to make such decisions at that site, park, or facility shall notify the participant or visitor of this decision and that the incident will be reported immediately to the District's ADA Coordinator. The employee shall then report the incident to the ADA Coordinator.

GURNEE PARK DISTRICT POLICY MANUAL

- 2) The ADA Coordinator (or designee) will investigate all reported concerns and incidents where service animals have been temporarily removed from sites, parks, and facilities. The ADA Coordinator (or designee) will consult with appropriate Department personnel and determine whether or not the animal should be excluded from sites, parks, and facilities for an extended period of time, permanently or for particular services, programs or activities due to the increased risk of harm or injury to the Partner/Trainer, the service animal or other participants. The ADA Coordinator (or designee) will notify the participant, authorized user, or visitor of their decision. All decisions will be made on a case-by-case manner based on the particular prevailing circumstances.
- 3) If it is appropriate for the service animal to be excluded from sites, parks, or facilities permanently, the ADA Coordinator (or designee) will work with other Department staff to attempt to ensure the participant, authorized user, or visitor receives appropriate reasonable modifications in place of the use of a service animal.
- 4) A participant, authorized user, or visitor who does not agree with the decision regarding removal from the premises may file an accessibility complaint.

4.4.8 Temporary Exclusion of an Employee's Service Animal:

- A. In response to an immediate concern, the District may determine that a service animal must be temporarily removed from sites, parks, or facilities. The Director (or designee) shall notify the employee of this decision and that the incident will be reported immediately to the District's ADA Coordinator. The Director (or designee) shall then report the incident to the District's ADA Coordinator.
- B. The ADA Coordinator will investigate all reported concerns and cases where service animals have been temporarily removed from sites, parks, and facilities. The ADA Coordinator will consult with appropriate staff and determine whether or not the animal should be excluded for an extended period of time, permanently or for particular services, programs or activities due to the increased risk of harm or injury to the Partner/Trainer, the service animal or other participants. The ADA Coordinator shall notify the employee of his or her decision. All decisions will be made on a case-by-case manner based on the particular prevailing circumstances.
- C. If it is appropriate for the animal to be excluded from sites, parks, and facilities permanently, the ADA Coordinator will attempt to ensure the employee receives appropriate accommodations in place of the use of a service animal.
- D. An employee who does not agree with the resolution may file an appeal or formal complaint following the District's ADA Process.

4.4.9 Conflicting Disabilities

Individuals with medical issues (such as respiratory diseases) who are affected by animals should contact the ADA Coordinator if they have a concern about exposure to a service animal. The individual will be asked to provide medical documentation that identifies a disability and the need for an accommodation. The appropriate District staff will facilitate a process to resolve the conflict that considers the needs and conditions of all persons involved.

4.4.10 Clarifying an Animal's Status

It may not be easy to discern whether or not an animal is a service animal by observing the animal's harness, cape, or backpack, or the partner/handler's disability. However, in other cases, an animal may only have a leash, and in still other situations, the partner/handler's disability is not apparent. Therefore, it may be appropriate for designated District staff such as managers, supervisors, or administrative staff to ask (1) whether the animal is required because of a disability, and (2) what work or task the animal has been trained to perform.

4.4.11 Emergency Situations

Emergency Responders (ERs) are trained to recognize service animals and to be aware that animals may try to communicate the need for help. Also, an animal may become disoriented from the smell of smoke in a fire or facility emergency, or from sirens, wind noise, or shaking and moving ground. A partner/handler, service animal, and team may be confused in any stressful situation. ERs will remember that animals may be trying to be protective and, in its confusion, should not be considered harmful. ERs should make every effort to keep a service animal with its partner/handler; however, the ER's first effort should be toward the partner/handler, which may result in the animal being left behind in some emergency evacuation situations.

4.4.12 Miscellaneous

- A. The District accepts no responsibility for care of service animals.
- B. The District accepts no liability for injury to any service animal, or injury to the handler/partner, whether caused by the animal, its handler/partner, another visitor to a District facility or site, the physical conditions of the District facility or site, or any other circumstance.
- C. The District accepts no liability for damage or injury to others caused by a service animal.
- D. The District accepts no liability for any injuries or property damage, to the service animal, its handler/partner, or others, resulting from the District's failure to enforce this policy or to supervise a service animal.
- E. The District reserves the right to change, modify, or amend this policy at any time.

4.5 Revenue Policy

Statement of Purpose

The mission of the Gurnee Park District is *Promoting Fun and Preserving Nature*. To do so it is necessary to supplement the tax dollars the District receives through a system of fees and charges. This policy establishes a method of setting activity, membership and facility use fees.

Administration of the Policy

4.5.1 Pricing Strategies and Structures

The District acknowledges that the majority of recreation services should be self-sustaining and preferably contribute to the indirect costs of the program. All fees are established by the Executive Director who also has the authority to waive or lower any fees when deemed to be in the best interest of the District. Recreation activities are categorized into classifications as per the document titled “categories of services” which is reviewed and approved annually by the Board of as the beginning of the budget process.

4.5.2 Establishing Fees: Special Situations and Groups

A. Non-Residents

Non-residents are defined as individuals who do not live within the boundaries of the District. Since non-residents pay no taxes to help support District operations, it is reasonable and equitable to charge higher fees to non-residents. Non-resident fees are established based on the District's need to supplement program and facility use. Non-resident fees are traditionally set at 25% for most programs but this may be changed by the Executive Director if deemed in the best interest of the District.

B. Financial Hardship

Assistance in the form of a complete or partial fee waiver shall be provided to District residents who show financial need as documented in the confidential Financial Assistance application and as allowed under the Financial Assistance Policy.

C. Not for Profit Organizations

Discount rates for Not for Profit Organizations, such as churches, girl scouts, or civic groups, may be established which are equal to or less than resident rates. Discount rates may vary on a facility-by-facility basis.

D. Proprietary or Commercial Groups

Proprietary or commercial groups using park facilities for financial gain or profit may be charged additional fees for the privilege of conducting their business on park property.

E. Corporate Residents

The District may offer programs and services to employees at local businesses at discounted rates for certain programs and memberships. Businesses owners located within the district boundaries that pay taxes to help support district operations are considered to be district residents.

GURNEE PARK DISTRICT POLICY MANUAL

4.5.3 Satisfaction Guarantee

The 100% satisfaction guarantee is based on keeping the District's promise to provide quality recreation programs. If participants are not satisfied with the recreational program, event or activity the District provides due to:

- the quality of instruction,
- the child's inability to adapt emotionally to the class,
- or the skill level is not appropriate for the participant

The district will arrange for participants to:

- receive full credit that can be applied to any other program
- or receive a refund

Satisfaction guarantee requests can be initiated in person, by calling, writing, or emailing the district. Participants must also attend at least two days of the activity to determine if the above mentioned criteria will be satisfactory and to give program staff the appropriate opportunity to deliver satisfactory services.

4.5.4 Grants, Gifts, Donations, and Bequests

The District may accept grants, gifts, service-in-kind, bequests, or donations to the District for the purposes of acquisition of park land, planning, development, maintenance, operations, and administration of parks and recreation facilities and programs. The Board authorizes the Executive Director to accept on behalf of the District non-governmental grants, service-in-kind, and gifts, donations, or bequests of cash or personal property valued at \$25,000 or less, provided the solicitation, acceptance and use of these revenues and/or gifts are consistent with state law and local ordinances and are in the best interest of Park District residents. Gifts, grants, service-in-kind, donations, or bequests valued at more than \$25,000 must have Board's approval. Any gift or bequest of real estate and all governmental grants may be accepted only by the Board.

All gifts, bequests, and donations of personal property or real estate and all grants shall be held, used, or disposed in accordance with the terms and conditions under which the gift, bequest, donation, or grant is made and accepted in accordance with state law of Park District Code. The Executive Director and/or the Board may reject any gift, bequest, or service-in-kind for just cause.

4.6 Abused and Neglected Child Reporting

Statement of Purpose

The District will maintain a policy and procedure covering the requirements of the Abused and Neglected Child Care reporting Act (325 ILCS 5/4, Ch. 23).

Administration of the Policy

As the District serves a significant number of children in its programs and services, it is mandated to comply with the Abused and Neglected Child Care Reporting Act. The act requires staff who have a reasonable cause to believe a child may have been abused or neglected shall immediately report or cause a report to be made to the Department of Children and Family Services. Under no circumstances shall any person in charge of any or all part of the District exercise any control, restraint or modification or other change in the report or the forwarding of such report to the Department.

The phone number to report abuse or neglect is 1-(800) 25 ABUSE, (1-(800)-252-2873), or (1-(217)-524-2606).

4.7 Recreation Planning, Development and Evaluation Policy

Statement of the Policy

The Gurnee Park District will seek input from the community and participants in the planning, development and evaluation of recreation programs and services.

Administration of the Policy

To comply with the Recreation Planning, Development and Evaluation Policy, the following procedures should be utilized:

- **Suggestion Box**

A suggestion box is in the lobby of each facility in the effort to have community members and/or participants share their ideas and suggestions.

- **Focus Group**

In “major” programming areas, a “focus group” comprised of program participants chosen at random, may be held every 3-5 years, to determine satisfaction in programs, customer service, instructors, facilities and program content. The focus group will be facilitated by the Director of Recreation or Recreation Manager. At this time a general question will also be asked about other programs they would like to see developed at the park district. “Major” program areas include, but are not limited to youth athletics, Camp, CARE, Aquatics, Preschool, Dance, Program Guide and Fitness Center.

- **Program Evaluations**

Evaluations will be e-mailed to program participants on a rotation and schedule. All programs, including contractual programs, will be surveyed at least once per year. Large program areas such as swimming and dance will be surveyed twice each year.

When a community member or participant fills out the proposal form, “Let us know how we are doing” form, or suggestion box form, it will be sent to the Director of Recreation or designee to investigate comment, suggestion and possibly implement if it meets the mission of the Gurnee Park District and there is a documented need for the program.

Program Evaluation results will be tabulated and given to the Director of Recreation and reviewed with the appropriate program manager/supervisor. Changes, suggestions or additions to programs may be determined from these evaluations.

4.8 Soccer Goal Safety and Education Policy

Statement of Purpose

Introduction and Identification of Act

This Soccer Goal Safety and Education Policy (“Policy”) is adopted pursuant to the Illinois Movable Soccer Goal Safety Act, also known as Zach’s Law, 430 ILCS 145/ (the “Act”). The Act requires Gurnee Park District to create a policy to outline how it will specifically address the safety issues associated with movable soccer goals.

Definitions

The following words shall have the following meanings when used in this Policy.

“**Act**” means the Illinois Movable Soccer Goal Safety Act, also known as Zach’s Law, 430 ILCS 145/.

“**Authorized Personnel**” means Permitted Users and all District employees who have responsibility for or contact with Movable Soccer Goals.

“**Board**” means the Board of Commissioners of the District.

“**District**” means Gurnee Park District.

“**Movable Soccer Goal(s)**” means a freestanding structure consisting of at least 2 upright posts, a crossbar, and support bars that is designed: (1) to be used for the purposes of a soccer goal; (2) to be used without any form of support or restraint other than pegs, stakes, augers, counter-weights, or other types of temporary anchoring devices; and (3) to be able to be moved to different locations.

“**Organization**” means any unit of local government other than the District, and any school district, sporting club, soccer organization, religious organization, business, or other similar organization.

“**Permitted User(s)**” means an Organization and all of its employees, agents, coaches and volunteers that use Property for Soccer-Related Activities.

“**Policy**” means this Soccer Goal Safety and Education Policy.

“**Property**” means real property owned or leased by the District where Movable Soccer Goals are used.

“**Safety Guidelines**” mean the Guidelines for Safely Securing Movable Soccer Goals attached to this Policy as Attachment 1.

“**Soccer-Related Activity**” means use of Movable Soccer Goals on Property, including without limitation, soccer games, scrimmages, practices and the like.

Administration of the Policy

4.8.1 Moving and Securing Movable Soccer Goals; Warning Labels

Prior to the commencement of the soccer season each year, the District will place and secure Movable Soccer Goals on its Property in accordance with the Safety Guidelines. Only the District shall be permitted to move any Movable Soccer Goal the District owns, installs, or places on its Property.

Thereafter, if a Movable Soccer Goal becomes unanchored or improperly secured, only Authorized Personnel shall be permitted to re-secure it in accordance with the Safety Guidelines.

A warning label such as the following shall be posted on all Movable Soccer Goals:

ONLY AUTHORIZED PERSONNEL MAY MOVE AND ANCHOR THIS GOAL. IF THIS GOAL IS NOT ANCHORED DOWN, DO NOT USE IT AND CONTACT GURNEE PARK DISTRICT AT 847-623-7788. SERIOUS INJURY INCLUDING DEATH CAN OCCUR IF IT TIPS OVER.

4.8.2 Routine Inspections by District

The District shall routinely inspect all Movable Soccer Goals that the District has installed or placed onto its Property to verify that they are properly secured and document such inspection in writing.

4.8.3 Permitted User Inspections, Placement in Non-Use Position and Notice to Players

As a condition of the use of Property, before and after any Soccer-Related Activity, Permitted Users shall make a physical inspection of each Movable Soccer Goal to assure that the goal is secure in accordance with the Safety Guidelines. If any Movable Soccer Goal is not properly secured, the Permitted User shall secure the goal in accordance with the Safety Guidelines. If the Permitted User does not have the necessary equipment to secure the goal in accordance with the Safety Guidelines, the Permitted User shall place the goal in a non-use position by laying it forward onto its front bars and crossbar and shall immediately notify the District of the location of the goal.

As a condition of the use of Property and prior to the commencement of the soccer season each year, each Organization shall advise their players and the players' parents and guardians that Movable Soccer Goals may not be moved and that any use of a Movable Soccer Goal that is inconsistent with Soccer-Related Activity is strictly prohibited, including without limitation, playing, climbing, or hanging on any part of the Movable Soccer Goal. According to the U.S. Consumer Product Safety Commission, these activities can result in serious injury, including death. A sample notice is attached hereto as Attachment 2.

4.8.4 Use of District Property by Permitted Users

A copy of this Policy shall be provided to all Organizations using the Property for Soccer-Related Activity. Prior to using Property for Soccer-Related Activity, each Organization

GURNEE PARK DISTRICT POLICY MANUAL

shall provide each of its Permitted Users with a copy of this Policy and shall require that each of its Permitted Users comply with all applicable provisions of this Policy.

4.8.5 Removal

At the conclusion of each soccer season, the District will either remove all Movable Soccer Goals that it has installed or otherwise placed on its Property and store such goals at a secure location or otherwise secure such goals on its Property by placing the goal frames face to face (front posts and crossbars facing toward each other) and securing them at each goalpost with a lock and chain; or locking and chaining the goals to a suitable fixed structure such as a permanent fence; or locking unused portable goals in a secure storage room after each use; or fully disassembling the goals for season storage.

4.8.6 Acquisition of Tip-Resistant Movable Soccer Goals

After the effective date of this Policy, the District will not purchase any Movable Soccer Goal unless it is tip resistant. A Movable Soccer Goal whose inside measurements are 6.5 to 8 feet high and 18 to 24 feet wide is not tip-resistant unless it conforms to the American Society for Testing and Materials (ASTM) standard F2673-08 for tip-resistant Movable Soccer Goals or is otherwise equipped with another design-feature approved by the U.S. Consumer Product Safety Commission. Notwithstanding the foregoing provisions, the District may continue to use its existing goals in a manner consistent with this Policy.

4.8.7 Applicability

If any provision of this Policy conflicts with any provision of the Act, the provisions of the Act shall prevail.

This Policy shall not create any new liability or increase any existing liability of the District, or any of its officers, employees, or agents, which exists under any other law, including but not limited to the Local Governmental and Governmental Employees Tort Immunity Act, 745 ILCS 10/1-101 *et seq.* Nor shall this Policy alter, diminish, restrict, cancel, or waive any defense or immunity of the District or any of its officers, employees, or agents, which exists under any other law, including but not limited to the Local Governmental and Governmental Employees Tort Immunity Act, 745 ILCS 10/1-101 *et seq.*

4.8.8 Availability of Policy

All District employees who have responsibility for or contact with Movable Soccer Goals shall be advised of this Policy.

A copy of the Policy is available to all other employees and any member of the public by requesting a copy from FOIA Officer at 847/623-7788 or through the District website, www.gurneeparkdistrict.com.

4.8.9 Amendments

This Policy may be amended by the District at any time.

GURNEE PARK DISTRICT POLICY MANUAL

4.8.10 Effective Date

This Policy became effective August 16, 2011 as approved by the Board of Park Commissioners.

ATTACHMENT 1

NOTE: The Guidelines for Movable Soccer Goal Safety published by the U.S. Consumer Product Safety Commission state that there are several different ways to properly secure a soccer goal and that the number and type of anchors to be used depend on a number of factors, such as soil type, soil moisture content, and total goal weight. The following guidelines are taken from the CPSC recommendations for Anchoring/Securing/Counterweighting goals. It is advisable to adapt Attachment 1 to the extent the recommendations are appropriate to a District's particular situation.

GUIDELINES FOR SAFELY SECURING MOVABLE SOCCER GOALS

According to the U.S. Consumer Product Safety Commission (CPSC), a properly anchored / counter-weighted movable soccer goal is much less likely to tip over. Accordingly, it is **IMPERATIVE** that **ALL** movable soccer goals are always anchored properly (e.g., see Figure 2 below) and that they are secured to the ground (preferably at the rear of the goal), making sure the anchors are flush with the ground and clearly visible.

There are several different ways to secure a Movable Soccer Goal. The number and type of anchors to be used will depend on a number of factors, such as soil type, soil moisture content, and total goal weight. Each goal shall be secured in accordance with the appropriate anchoring system as set forth below.

In addition, warning labels required by the District's Soccer Goal Safety and Education Policy will be attached to each goal. Nets shall be secured to posts, crossbars, and backdrops with tape or Velcro straps at intervals of no less than one every four feet.

Illustrations and Recommendations according to the U.S. Consumer Product Safety Commission

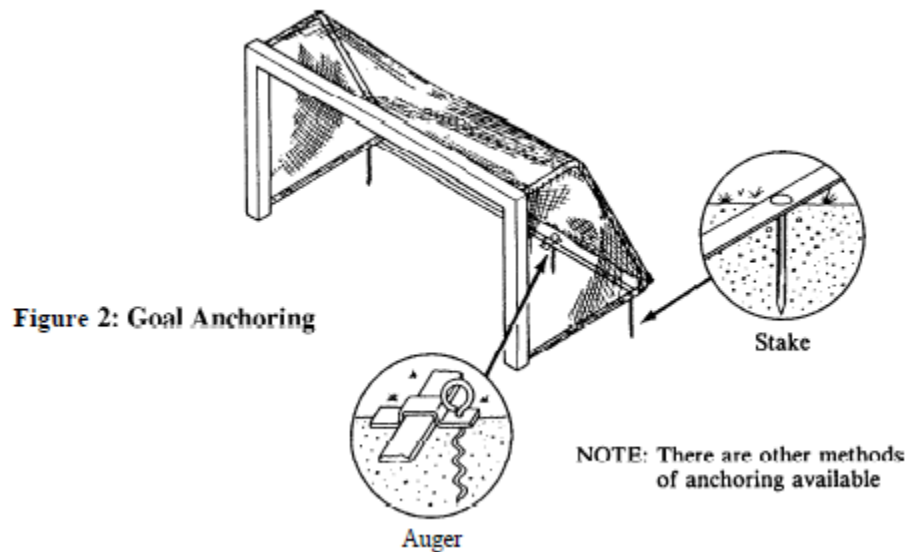

Attachment 1 - continued

Anchor Types

1. Auger style

This style anchor is “helical” shaped and is screwed into the ground. A flange is positioned over the ground shoes (bar) and rear ground shoe (bar) to secure them to the ground. A minimum of two auger-style anchors (one on each side of the goal) are recommended. More may be required, depending on the manufacturer’s specifications, the weight of the goal, and soil conditions.

Figure 3.1: Auger Style Anchor



2. Semi-permanent

This anchor type is usually comprised of two or more functional components. The main support requires a permanently secured base that is buried underground. One type (3.2a) of semi-permanent anchor connects the underground base to the soccer goal by means of 2 tethers. Another design (3.2b) utilizes a buried anchor tube with a threaded opening at ground level. The goal is positioned over the buried tube and the bolt is passed through the goal ground shoes (bar) and rear ground shoe (bar) and screwed into the threaded hole of the buried tube.

Figure 3.2a: Semipermanent Anchor

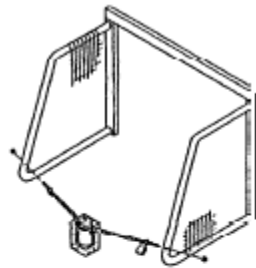
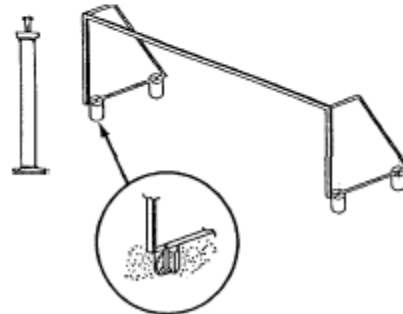

Figure 3.2b: Semipermanent Anchor



3. Peg or Stake style (varying lengths) Anchor

Typically two to four pegs or stakes are used per goal (more for heavier goals) (Figure 3.3). The normal length of a peg or stake is approximately 10 inches (250mm). Care should be taken when installing pegs or stakes. Pegs or stakes should be driven into the ground with a sledge-hammer as far as possible and at an angle if possible, through available holes in the ground shoes (bar) and rear ground shoe (bar) to secure them to the ground. If the peg or stake is not flush with the ground, it should be clearly visible to persons playing near the soccer goal. Stakes with larger diameters or textured surfaces have greater holding capacity.

Figure 3.3: Peg or Stake Style Anchor

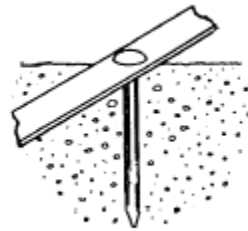

4. J-Hook Shaped Stake style

This style is used when holes are not pre-drilled into the ground shoes (bars) or rear ground shoe (bar) of the goal. Similar to the peg or stake style, this anchor is hammered, at an angle if possible, directly into the earth. The curved (top) position of this anchor fits over the goal member to secure it to the ground (Figure 3.4). Typically, two to four stakes of this type are recommended (per goal), depending on stake structure, manufacturers specifications, weight of goal, and soil conditions. Stakes with larger diameters or textured surfaces have greater holding capacity.

Figure 3.4: J-Hook Anchor

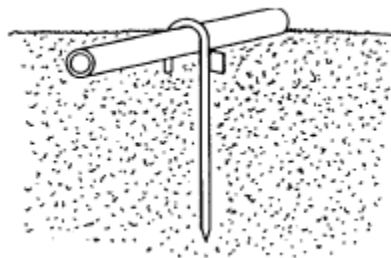

5. Sandbags/Counterweights

Sandbags or other counterweights could be an effective alternative on hard surfaces, such as artificial turf, where the surface cannot be penetrated by a conventional anchor (i. e., an indoor practice facility) (Figure 3.5). The number of bags or weights needed will vary and must be adequate for the size and total weight of the goal being supported.

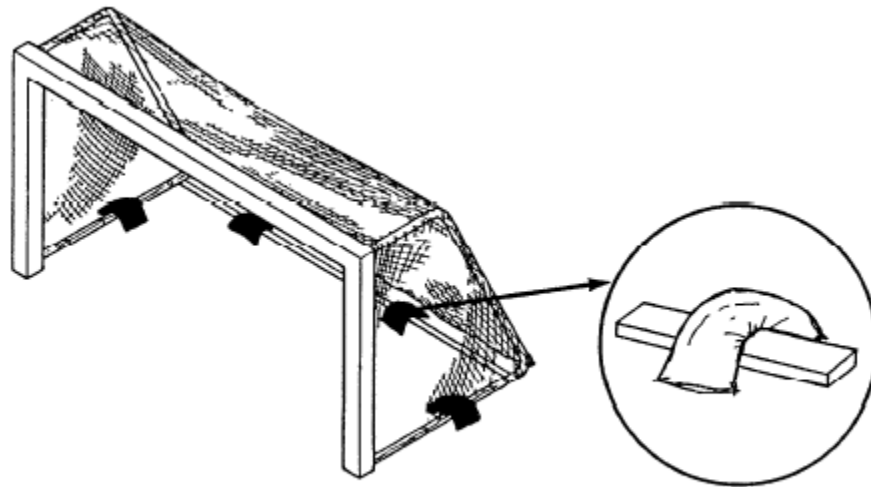

Figure 3.5: Sandbag Method of Anchoring

(Rear) Ground Bar/Shoe

6. Net Pegs

These tapered, metal stakes should be used to secure only the NET to the ground (Figure 3.6). Net pegs should NOT be used to anchor the movable soccer goal.

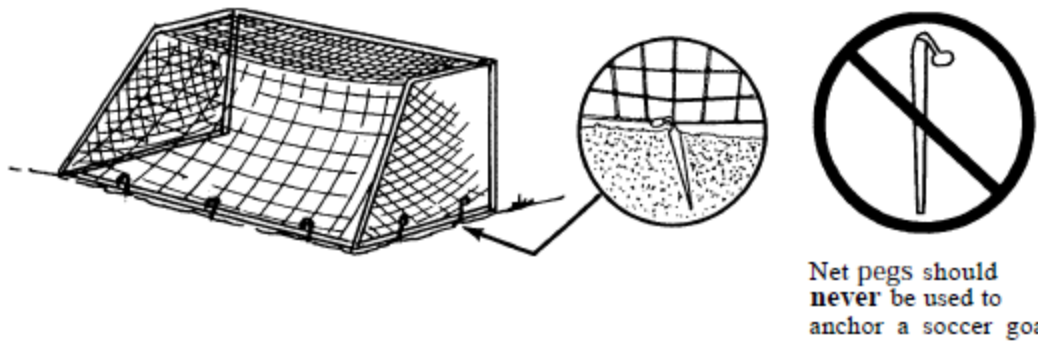

Figure 3.6: Net Pegs

Net pegs should **never** be used to anchor a soccer goal

GURNEE PARK DISTRICT POLICY MANUAL

**ATTACHMENT 2
SAMPLE NOTICE**

[INSERT DATE]

TO WHOM IT MAY CONCERN: All parents and guardians of soccer players:

One of our primary objectives is that children have safe recreation areas. To that end, soccer goals should remain securely anchored to the ground and nets firmly attached to the goals.

In an effort to keep the goals and nets secure and children safe, you are required to advise your children/soccer players and any other person accompanying you for whom you are responsible that the following is strictly prohibited: moving any soccer goals and any use of a soccer goal that is inconsistent with soccer-related activity, including without limitation, playing, climbing, or hanging on any part of the soccer goal. This especially applies to children climbing on or hanging from nets or goal frames. According to the U.S. Consumer Product Safety Commission, these activities can result in serious injury, including death.

If you observe any child inappropriately using a soccer goal or net, immediately and politely ask the child to stop. If the activity continues, please notify a coach or referee as soon as possible. Players violating this rule may be forced to sit out, at the coach's discretion.

Finally, if you see any soccer goal that is not anchored down or any net that is not firmly secured to the goal, please notify a coach or referee immediately.

Sincerely,

Gurnee Park District

4.9 Financial Assistance Policy

Statement of Purpose

The Gurnee Park District provides financial assistance/scholarships to residents who are interested in enrolling in a District program, but unable to do so due to financial hardships. Based on available funds the district may also offer financial assistance to applicants who reside outside of the Gurnee Park District but within the school district boundaries of District 50 or 56 for a CARE or Day Camp program where they are eligible to receive the resident rate. The Park District reserves the right to approve full or partial assistance or deny an applicant's request.

Administration of the Policy

Those who are seeking financial assistance must complete the Financial Assistance/Scholarship Application Form. Completed applications should be directed to the Director of Recreation located at the Hunt Club Community Center **at least three weeks prior to the start of the program (four weeks if it is a camp, CARE or preschool program)**. The applications will be individually reviewed and the applicants will be notified of the decision within three weeks after receipt of the completed application at which point a letter will be sent to the address on the application with the determination and further instructions. Awards are given after recommendation of eligibility is made by the Director of Recreation and approval by the Executive Director.

4.10 Volunteer Policy

Statement of Purpose

It is the intent of the Gurnee Park District to utilize volunteers to enhance and improve the quality of the overall operations and to offer opportunities for individuals to gain experience that may be useful in their future endeavors to secure employment or to fulfill community service desires they may have. The use of volunteers is not intended to replace payroll personnel, but to supplement our programs and services in non-hazardous environments.

Administration of the Policy

A Volunteer Coordinator shall be appointed by the Director of Recreation to recruit, assign, and retain volunteers for various activities throughout the District.

1. Prior to being accepted by the District as a volunteer, all individuals wishing to volunteer must complete a Volunteer Application Form for the area/event in which they wish to work. The Volunteer Application Form, in compliance with Illinois Law 70 ILCS 1205/8-23a, shall ask each applicant whether they have been convicted of or found to be a child sex offender.
2. The Volunteer Application Form will be forwarded to Volunteer Coordinator for the Park District. Once the form is received and reviewed, if the candidate is approved by the District, the volunteer will be assigned to the appropriate staff person for that activity.
3. The staff member in charge of the program/event will contact the volunteer (or meet them prior to the activity) to review details, arrange for training, schedule their assignments, etc. At times this may also be provided by the Volunteer Coordinator.
4. A criminal background check will be completed on volunteers who are 18 years and older who are placed in activities where there is direct instruction of children's activities, including, but not limited to sports coaches. As part of the criminal background check process, applicants will need to provide their Social Security Number.
5. Rewards and recognition may be awarded to volunteers based on the current Employee and Volunteer Recognition Policy.
6. Program Discounts may be awarded to volunteers of certain programs as approved by the Executive Director.

Confidentiality

The Gurnee Park District respects the privacy of volunteers and information received during a volunteer's screening process will not be disclosed outside of the organization (absent a legal need or duty to disclose to third-parties) and will be shared within the organization only on a "need to know" basis. This would include keeping the consent/release form (which includes personal data on the volunteer) in secure locations and only in the hands of authorized personnel. Volunteers should also be aware and

GURNEE PARK DISTRICT POLICY MANUAL

acknowledge that the organization might, in special circumstances, have a legal duty or need to disclose to third parties, including government agencies, certain types of information.

Applicable Legal Requirements

Gurnee Park District shall comply with all applicable federal, state and local laws regarding background checks for prospective volunteers.

Recommended Criteria for Exclusion

A conviction for any other offense that would prohibit the individual from employment under 70 ILCS 1205/8-23 would also disqualify an applicant to volunteer; however, the Gurnee Park District Reserves the right to be more stringent of this criteria to ensure a safe environment for its participants.

Nothing in this policy shall guarantee a person the right to volunteer with the District, and the District shall exercise its discretion as to whether to allow individuals to volunteer when they do not have convictions that automatically bar volunteering, such as those convictions referenced above.

Pending Cases

Anyone who has been charged for any of the disqualifying offenses or for cases pending in court should not be permitted to volunteer until the official adjudication of the case.

4.11 Employee and Volunteer Recognition Policy

Statement of Purpose

Gurnee Park District believe it is important to recognize achievements in the workplace by our staff and our volunteers and has developed this policy to guide decisions in recognizing those who contribute to the success of the organization and the delivery of services to the community.

Administration of the Policy

The following set of guidelines has been established to give noted staff the authority to provide recognition at varying levels:

“Above & Beyond” Performance Awards

This program is intended to provide management with tools to recognize contributions of employees and volunteers in a consistent manner. The following are guidelines for recognizing District employees for “above and beyond” performance on the job. Some examples of the type of work and behavior that needs to be recognized are listed below, and there may be many more areas that need acknowledgement, which should be determined by the Supervisor. A memo or thank you note letting the employees know what they are being recognized for should accompany all awards except those in Level 1. This program is not intended to eliminate the verbal and written recognition managers are expected to give on a regular basis.

4.11.1 Award Levels

The awards are divided into four levels. Following is a list of awards and their levels.

LEVEL 1

*(not to exceed \$5)
(Approved by Supervisor)*

\$5 Gift Cards
\$5 coupon to Cattail Café
GPD accessories <\$5
Motivational items

LEVEL II

*(not to exceed \$25)
(Approved by Dept. Head)*

Gift Cards
Movie gift cards
GPD Gift certificate
GPD accessories/apparel

LEVEL III

*(not to exceed \$50)
(Approved by Exec. Director)*

Gift Cards
Premier Choice Award
Free rental (SK or shelters)
½ day off

LEVEL IV – Team/Project Awards

(Approved by Executive Director)

Catered Lunch
Offsite Lunch or Breakfast
Team Building exercises – 1 hour

GURNEE PARK DISTRICT POLICY MANUAL

- 4.11.2 Level I Awards can be given out by any employee with approval from respective supervisor. Each Supervisor will be given a supply of items from this level which they can give out to employees as they see fit. Supervisors are responsible for keeping track of who they give the awards to and for what purpose. Supervisors can request additional items from the Finance Department when they are low on supply. Finance Department will be responsible for purchasing and keeping track of these recognition items.

The “motivational items” in this category can be determined and purchased by each supervisor based on the individual team’s needs. These should be low cost items and no more than \$200 can be spent on these items in any given fiscal year by each supervisor. Supervisors must notify the Director of Business Services regarding their purchase prior to or immediately after the purchase.

- 4.11.3 Level II accomplishments are determined by employee’s immediate supervisor and approved by the respective Director. The supervisor or Director can request the award item from the Finance Department. The Finance Department will keep track of the items as to who requested and who received the award.
- 4.11.4 Level III accomplishments are determined by employee’s immediate supervisor, then referred to the respective Superintendent and approved by the Executive Director.
- 4.11.5 Level IV accomplishments are determined by supervisors or Directors and approved by the Executive Director. Request must be made to the Executive Director prior to planning the lunch.

The employee should be allowed to select the award of their choice from the appropriate level whenever feasible.

4.11.6 Examples

Following are examples of accomplishments that will qualify an employee to receive one of the above awards for above and beyond expected performance.

- Extraordinary customer service
- Consistent positive attitude
- Assisting co-workers
- Voluntarily working extra hours
- Courageous leadership
- Exceeding pre-determined goals
- Exceptional teamwork
- Special achievements
- Expanding programs and increasing revenue/new program implementation

4.11.7 Training

Occasionally, food will be provided at trainings such as all-staff meeting, District-wide staff meeting, etc. Directors are authorized to purchase donuts, bagels etc. for staff meetings or any

GURNEE PARK DISTRICT POLICY MANUAL

other training sessions. Any other purchase of food for training purposes must be approved by the Executive Director.

4.11.8 Anniversary Awards

A Premiere Choice certificate in the amount of \$50, \$100, \$150, \$200 and \$250 will be given to employees on their 5, 10, 15, 20, and 25-year anniversaries respectively. Fulltime employees are eligible. This program is handled by the Business Services Department.

4.11.9 Not Acceptable

- Payments for celebrations such as birthdays, showers, non-work related milestones etc.
- The District will not pay for alcoholic beverages
- No gifts unless approved by Park Board
- No Holiday gifts

4.11.10 Annual Holiday Recognition Party

This event will be held to recognize full time and year-round part time employees. The District will provide a catered meal for both the employee and their guest. The District does not pay for any alcoholic beverages.

There may be other recognition parties provided by the District for employees who are not part of the above event. These must have prior approval by the Executive Director including amount and location.

4.11.11 Annual Summer Volunteer/Staff Recognition Party

This event features a pool party cookout at the Hunt Club Park Aquatic Center. The District will provide food for the employees and volunteers along with their guests. No alcoholic beverages are permitted. The party may be moved to another location in case of inclement weather.

4.11.12 Other Awards

The Executive Director has the discretion to approve other recognition awards. Any such award requested by staff must be obtained in writing.

4.12 Policy on Criminal Background Check for Contractual Program Providers

Statement of Purpose

Criminal background checks consistent with those required by Section 8-23 of the Park District Code (70 ILCS 1205/8-23) shall be conducted on all independent contractors teaching Park District programs or providing services at any Park District programs or facilities where the individual will be alone with children. Criminal background investigations may also be required for persons providing services in positions that have physical access to or control over cash or other public funds; persons, who by virtue of their position, have on a regular basis, individual unsupervised contact with or access to users of Gurnee Park District programs and/or facilities; or whenever the Executive Director determines necessary in the interest of public safety.

If the independent contractor is an organization with individuals employed by them providing services listed in the preceding paragraph, the organization shall be required to file signed authorization forms for each individual to submit to the criminal background checks or, in the alternative, provide results from criminal background checks already conducted by the organization signing the independent contractor agreement.

Administration of the Policy

Each year the Business Services Office will send an updated Contractual Agreement to the Program Supervisor overseeing that program area. After review, the Program Supervisor will make a recommendation to the Director of Recreation whether or not the agreement shall be renewed. If the agreement is renewed, the Business Services Office will send the contract to the appropriate contractual program provider for their approval. Evidence will be requested of a background check completed within the past year on themselves and all instructors that are to lead the activity. If the contractual provider does not have current background checks they have the option to:

1. Perform the background checks themselves and send us a copy of the completed background check(s).
2. Request a background check be conducted by the Gurnee Park District for them and their staff. If they choose this option, the necessary background check forms will be provided to them by the Business Services office with a return date indicated. Once the forms are submitted to the Gurnee Park District, at its own expense the District will run the background checks to confirm there are no concerns with their staff working with our participants.

Any background check reports containing criminal records shall be forwarded to the Program Supervisor to be reviewed with the Director of Recreation and a determination will be made if they will be permitted to perform these services. The Program Supervisor shall communicate any objections to the contractual program provider. The successful completion of a background check is a condition of the contractual agreement and the independent contractor or their staff may be disqualified from leading activities if the background check is concerning. Any background checks results that are not favorable will be sent to the Director of Recreation for review and a determination of their eligibility to lead activities.

GURNEE PARK DISTRICT POLICY MANUAL

APPENDIX A: PERSONNEL POLICY MANUAL

(add PDF)

GURNEE PARK DISTRICT POLICY MANUAL

APPENDIX B: SAFETY PROCEDURE MANUAL

(ADD PDF)